

**Heated Landing Shelf  
Prince Castle Model No. STB-36BF, & 48BF Series**



This equipment chapter is to be placed in the Miscellaneous Section of your *Equipment Manual*

**MANUFACTURED BY  
PRINCE CASTLE INC.  
355 EAST KEHOE BLVD  
CAROL STREAM, IL 60188 USA  
PHONE 1-630-462-8800  
TOLL FREE NUMBER  
1-800-323-2930  
FAX: 1-630-462-1460**



<b>WARRANTY</b> .....	<b>Page 1</b>
<b>INTRODUCTION</b> .....	<b>Page 2</b>
<b>PARTS IDENTIFICATION</b> .....	<b>Page 2-6</b>
<b>EXPLODED VIEW</b> .....	<b>Page 2-6</b>
<b>EQUIPMENT SET-UP AND CLOSE PROCEDURES</b> .....	<b>Page 7</b>
<b>ORDERING PARTS</b> .....	<b>Page 8</b>
<b>TROUBLESHOOTING GUIDE</b> .....	<b>Page 9</b>
<b>WIRING INFORMATION</b> .....	<b>Page 11</b>

**LIMITED WARRANTY**

This Product is warranted to be free from defects in material and/or workmanship for a period of two (2) years from date of original installation not to exceed 30 months from date of shipment from our factory. Any part or component **(with the exception of light bulbs)** which proves to be faulty in material and or workmanship within the warranty period will be replaced or repaired without cost to the customer for parts or labor. (At the option of Prince Castle, Inc.) This warranty covers on-location service (i.e., trip charges and or mileage). Travel mileage is limited to 100 miles (200 Kilometers) round trip (one trip per warranty) from an authorized service agency or its sub-service agency.

This warranty is subject to the following exceptions/conditions:

1. Any use of Non-Genuine Prince Castle Spare Parts voids this warranty.
2. All labor shall be performed during regular working hours. Overtime premium will not be covered
3. Damage caused by carelessness, neglect, and/or abuse (e.g., using wrong current, dropping, tampering with or altering electrical components, or improper cleaning) is not covered. Equipment damaged in shipment, by fire, flood or an act of God.

This Manual is for the Exclusive use of Licensees and Employees of McDonald's Systems, Inc.  
Printed In November 1996

## INTRODUCTION

The Heated Landing Shelf comes with adjustable lane dividers that can be realigned for existing or new products. The Heated Landing Shelf holds up to a 72 sandwich capacity with 12 product lanes for Model No. STB-36, or up to a 96 sandwich capacity with 16 product lanes for Model No. STB-48. Adjustable upper and lower heaters maintain correct temperatures at various locations.

This unit utilizes Radiant Energy to maintain food temperature. The Racks, Sides, Top, and Internal Air Temperature of the unit will remain relatively cool while in operation. The only parts of the unit with a Hot Surface are the Black Decks which contain the Radiant Heat Source. Please refer to this Operating Manual for Calibration. Check the Actual Food Temperature or Surface Temperature of the Black Decks with an appropriate thermometer. Measuring the Air Temperature IS NOT an indication of the Food Temperature.

### STB-36BF EXPLODED VIEW

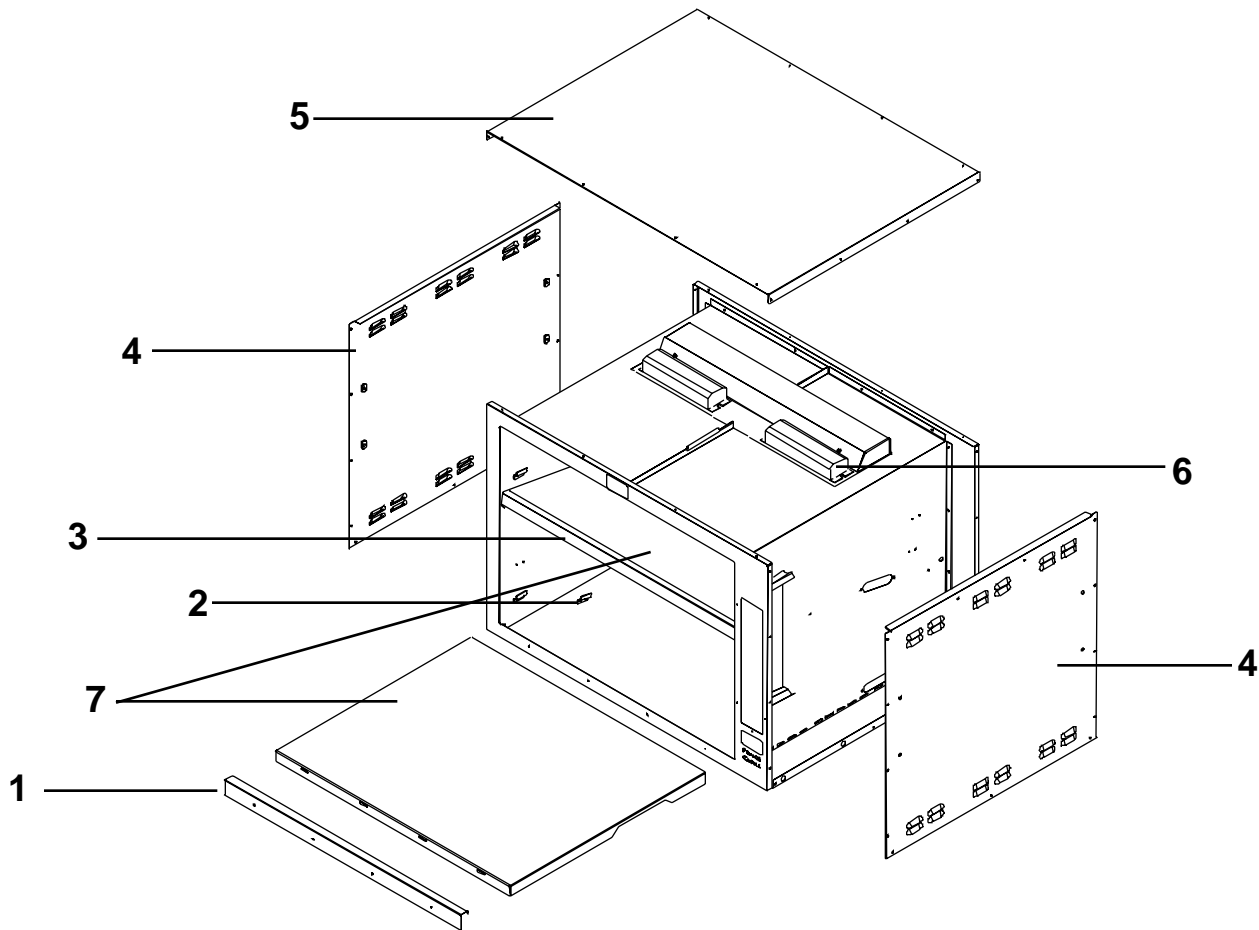

Item	Part #	Description
1	536-104	Lower Face
2	536-199S	Bracket w/Screws (pkg of 4)
3	536-420	Upper Face
4	536-139	Side Panel
5	536-120	Top Cover
6	536-601S	Ballast (240 Volt)
7	536-127S	Heater Assy
*	536-443	Lamp Guard (Not Shown)
*	72-200-16	Line Cord (Not Shown)
*	88-633-3S	Florescent Lamp (Not Shown)

## STB-48BF EXPLODED VIEW

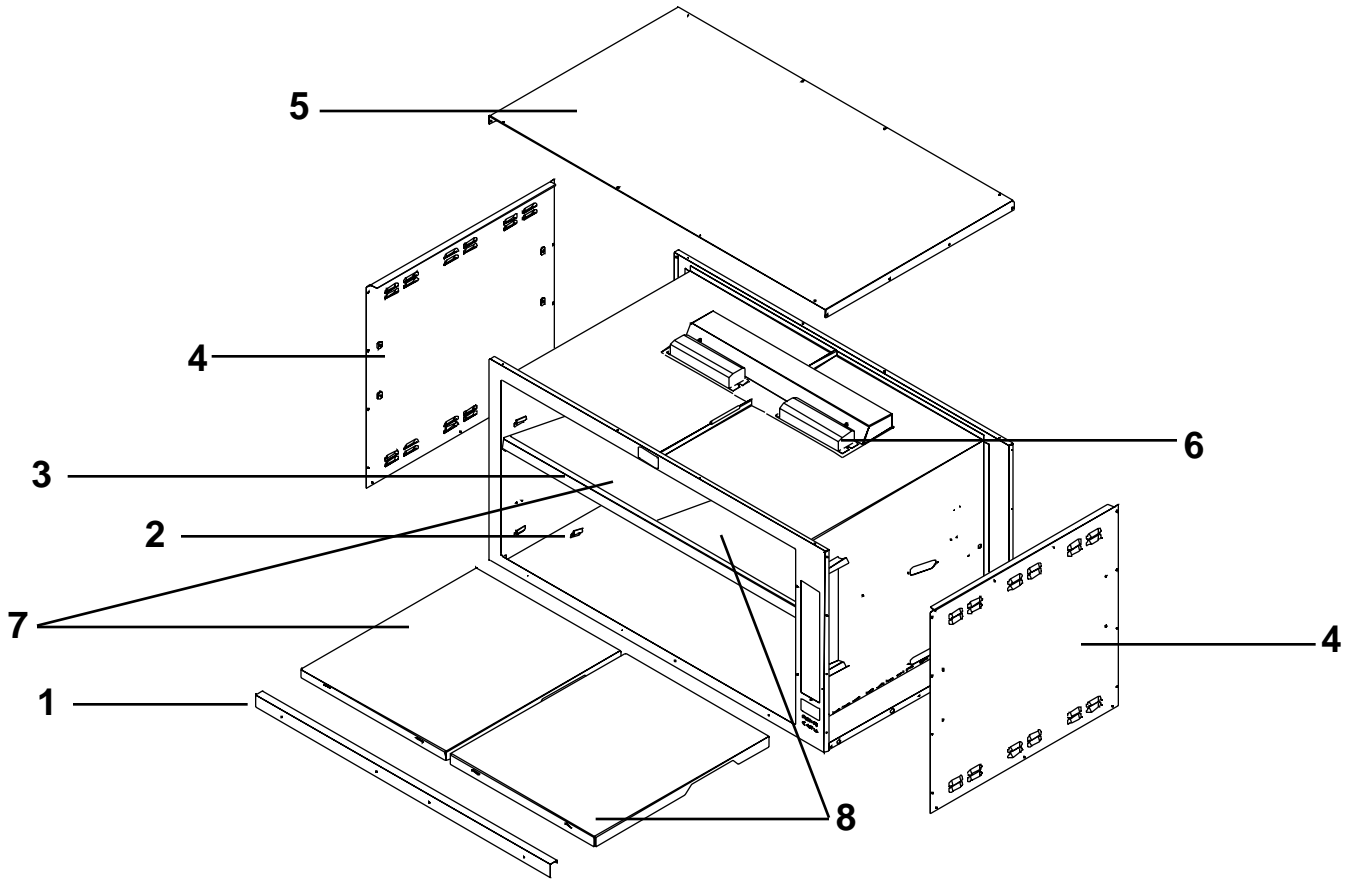

Item	Part #	Description
1	536-150	Lower Face
2	536-199S	Bracket w/Screws (pkg of 4)
3	536-414	Upper Face
4	536-139	Side Panel
5	536-148	Top Cover
6	536-601S	Ballast (240 Volt)
7	536-172S	Heater Assy. (Left Side)
8	536-255S	Heater Assy (Right Side)
*	536-443	Lamp Guard (Not Shown)
*	72-200-16S	Line Cord (Not Shown)
*	88-633-3S	Florescent Lamp (Not Shown)



## STB-48BF Control Box

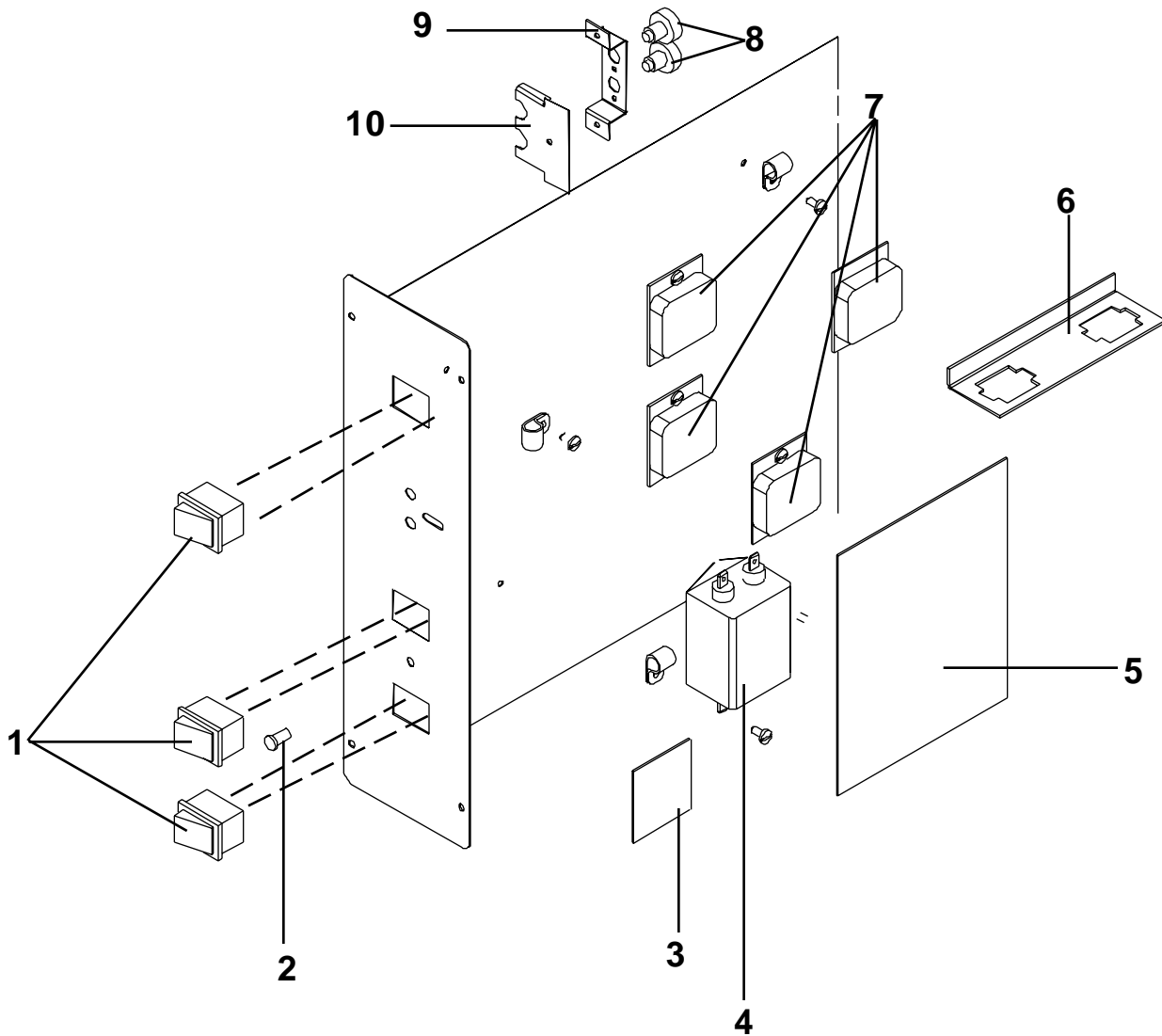

Item	Part #	Description	Item	Part	Description
1	78-184S	Lighted Rocker Switch	6	65-037S	Relay
2	536-348S	Status Light Assy.	7	411-133S	Potentiometer
3	88-626	Filter	8	536-317	Potentiometer Bracket
4	536-241	Connector Bracket	9	536-33	Potentiometer Door
5	536-197S	Control P.C.Board Assy.	10	421-208S	P.C. Board

## STB-36BF & STB-48BF Heated Landing Shelf Accessories

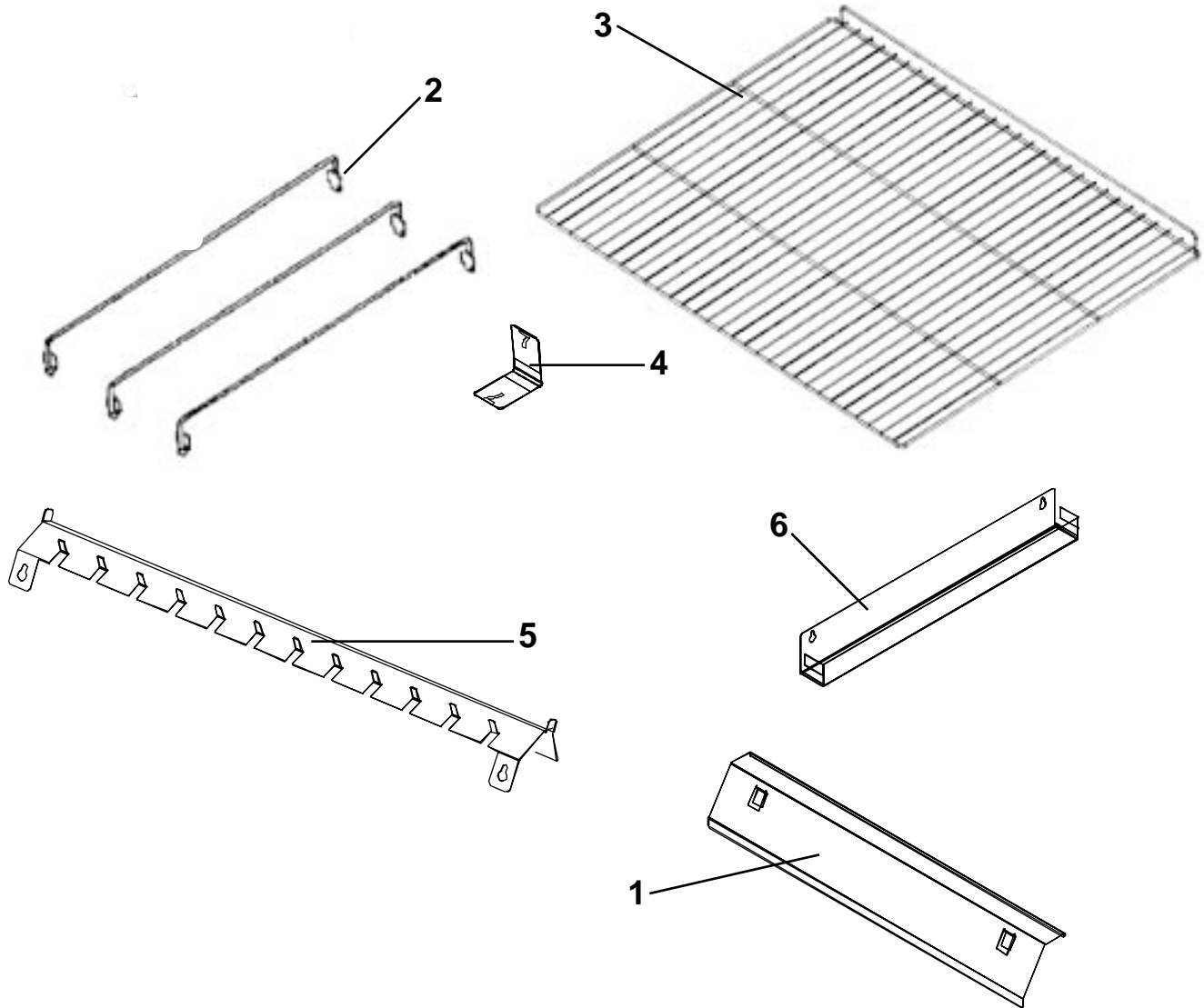

Item	Part #	Description
1	536-218	Lane Divider
2	536-213	Wire Rack (FHB-36)
	536-214	Wire Rack (FHB-48)
3	536-131	Time Card Storage Rack (FHB-36)
	536-167	Time Card Storage Rack (FHB-48)
4	536-391QS	Time Card Kit
5	536-132	Time Card Return Rack
6	536-411	Left Side Tray Bracket
7	536-412	Right Side Tray Bracket
*	536-410	Center Tray Bracket (FHB-48 Only) (Not Shown)
8	536-421	Tray Rod (FHB-36)
	536-413	Tray Rod (FHB-48)

\* Individual replacement time cards are available in packages of three. Contact Prince Castle or a local Prince Castle Service Agent.

## EQUIPMENT SET-UP AND CLOSE PROCEDURES

1. Place Heated Landing Shelf on counter and seal it completely with a food approved sealant.

2. Insert Power Cord into a proper voltage receptacle  
NOTE: This should be a dedicated outlet. No other equipment should be operating on this line (i.e. fryers, refrigerators, cash registers, etc.)

3. Snap in Wire Racks with lip toward counter. The Lower Rack can be set at an angle by setting the rear (Kitchen Side) Part of the racks in the upper brackets located on the sides of lower shelves. The upper rack adjustment is located in the front (Counter Side).

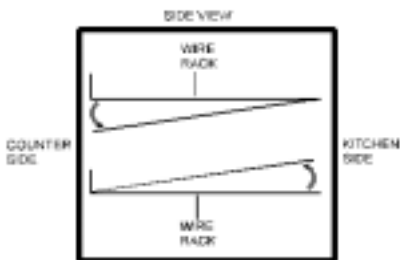

4. Attach Air Baffles By Sliding the two hooks located on the air baffle over the top (restaurant side) of the wire rack. **Note:** The rack in the upper compartment should be positioned at a downward angle by setting the restaurant side of the wire rack in the lower rack brackets located on the sides of the bin. The lower compartment rack may be positioned at either a horizontal or angled position.

5. Lane Dividers can be easily lifted out and moved to accommodate different size products.

6. The Time Card Storage Rack will be mounted on the top of the landing shelf on the kitchen side.

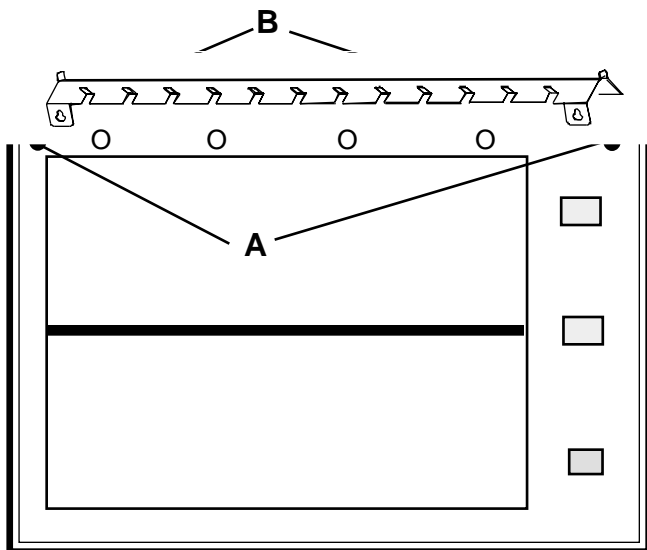

FIGURE 1

7. Loosen the two Phillips Head screws (A) on both sides of the bin. **NOTE: The screws only need to be loosened 2-3 turns DO NOT REMOVE.** (See Figure 1)

8. Place key hole slots (B) on the time card rack over the loosened screws and tighten. (See Figure 1)

9. The Time Card Return Rack can be mounted on either side of the Heated Landing Shelf.

10. Loosen two Phillips Head screws (A) one on top and one on bottom so the rack sits at an angle on side of the bin. **NOTE: The screws only need to be loosened 2-3 turns DO NOT REMOVE.** (See Figure 2)

11. Place key hole slots (B) on the time card return rack over the loosened screws and tighten. (See Figure 2)

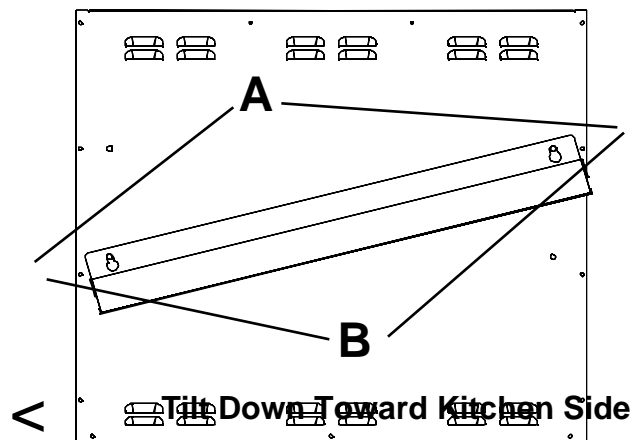
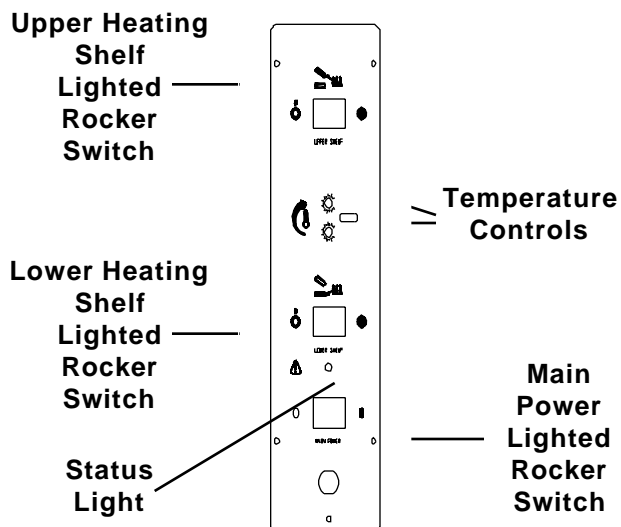

FIGURE 2

12. Turn on the Lighted Rocker Switch marked **MAIN POWER**.



13. Turn on the lighted rocker switches marked **UPPER HEATER** and **LOWER HEATER**. The lights and heaters will come on for both shelves and the unit will begin to heat up. Allow 30 minutes for warm-up.

**NOTE: The UPPER And LOWER shelves can be operated as two separate areas. During slow periods one shelf may be used while the other shelf is switched off.**

14. Refer to the operations and training manual for correct holding times.

### CLOSE PROCEDURES



**This appliance is not of water tight construction. Do not clean with a Water Jet / Jet Spray. Do not immerse appliance in water.**

CAUTION: Before unplugging Power Cord make sure all Power Switches are in the "OFF" position.

1. Unplug Heated Landing Shelf.
2. Allow unit to cool down. (Approximately 15 minutes)
3. Wipe down with a damp cloth.

**Caution: When cleaning do not pour water on the heaters. This may cause an electrical hazard and damage to the sensitive solid state circuitry. Do not use Grill Cleaner**

## INSPECT CARTON

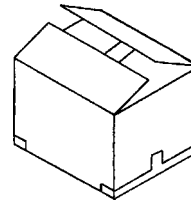

Remove product from carton.

If damaged:

- Notify carrier within 24 hours.
- Save carton and packing material.
- Prince Castle can assist with freight claims and arranging for a replacement unit if field repair is impossible, or if you find a part or parts missing In the USA Contact Prince Castle at 1-800-323-2930 outside the USA contact your KES or your Local Distributor.

## PARTS

1. Always refer to the Parts List in this manual. You will then have a part number for reference when ordering.
2. All replacement parts should be purchased from your local Prince Castle Service Center (see enclosed list). Outside the U.S.A contact your local Prince Castle Distributor.
3. RETURNS: All inoperable warranty parts must be returned to the Service Center.

## STB-36BF & STB-48BF P.C. Board Diagnostics

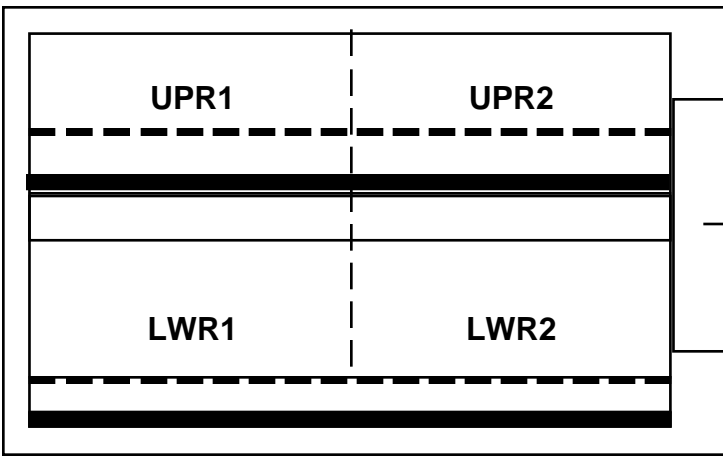

Control Panel

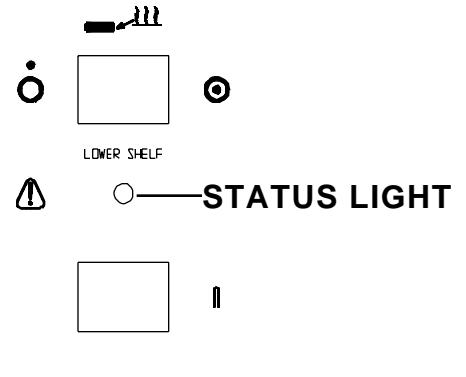

### Status Light Diagnostic Troubleshooting

The main purpose of the Status Light is to signal the operator that the Heated Landing Shelf is functioning properly.

□ Under normal conditions the **Status Light** will be a **steady green**.

□ Under a condition of malfunction, the **Status Light** will **flash red**. At this point switch off either heater, if the **Status Light** turns back to a **steady green** when you turn off a particular heater the malfunction is related to the switched off heater.

**NOTE:** Never turn off the **Main Power Switch** when experiencing a flashing red this will reset the **Status Light**. A reset **Status Light** takes 20 minutes to warm back up.

□ The **Status Light** should never be off, **amber/yellow**, or a **steady red**. Should this be the case, then the electronics driving the **Status Light** itself has malfunctioned.

**NOTE:** Once you have determined which heater compartment has malfunctioned, locate the diagnostic LED's on the P.C. Board. Follow the Diagnostic Troubleshooting on page 9 of this manual.

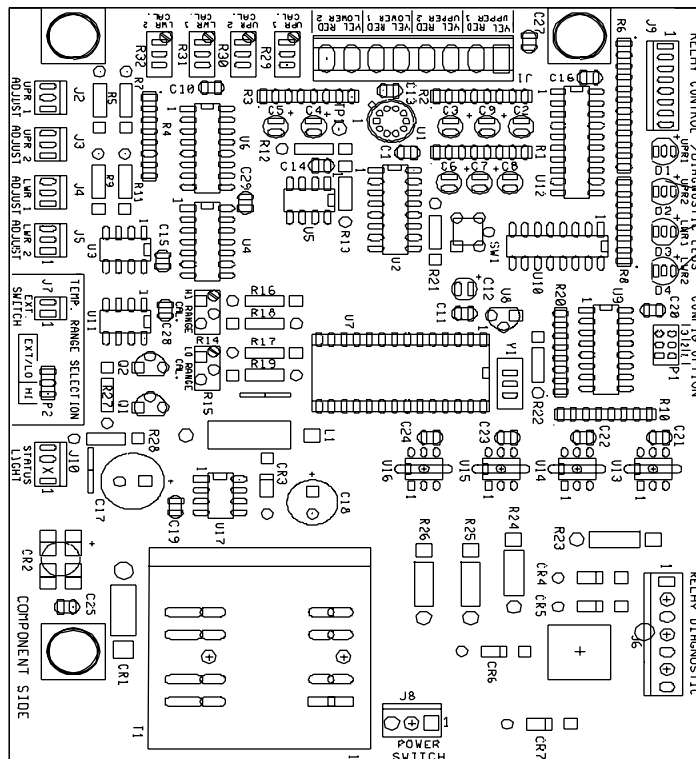

Diagnostic LEDs





# HEATED LANDING SHELF

CARD NO.  
72

## Planned Maintenance System Maintenance Requirement Card (MRC)

### Temperature & Calibration of STB Series Heated Landing Shelf

The Heated Landing Shelf leaves the factory with the plate temperature set at 225°- 230°F (107°- 110°C) for Models STB-22 & STB-11 and 235°- 240°F (113°- 116°C) for Models STB-36 & STB-48. Readings with the Surface Probe should be taken at the surface of the heaters 2" to the right of the center circle marking on top and bottom (See Figure Below). **NOTE: Because the location of the Heated Landing Shelf may vary from restaurant to restaurant there may be need to adjust the temperature setting due to climate control conditions in that location.**

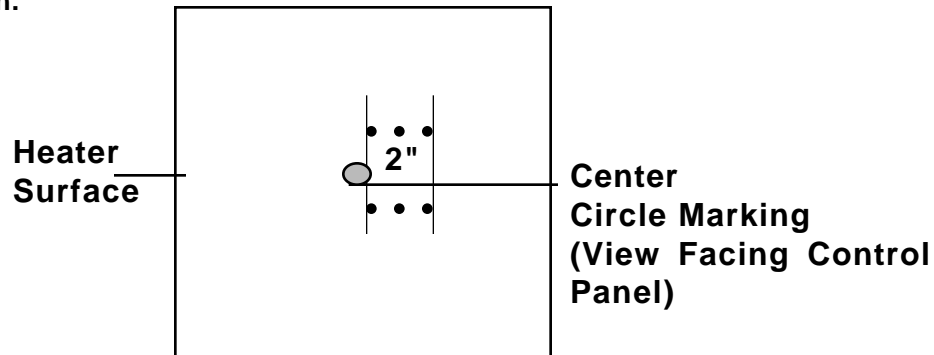

The following "Water Test" is intended for use only when the integrity of the Heated Landing Shelf is questioned by regulatory agencies, ie; health department, etc.

#### MATERIALS REQUIRED:

1 ea. 8 oz paper (**CAUTION:** Do not use Waxed Paper Cup) or styrofoam coffee cup with lid (lid may be plastic).  
1 ea. "K" type thermometer and probe, or a conventional bulb type thermometer capable of reading in the 100°-200°F Range (35°-100°C).

#### PRODUCT SIMULATION:

Place 4 tablespoons (1/4 cup) (60cc) of water in the paper cup. Use hot water, or microwave until the temperature of the water measures 155°-160°F (68°-71°C) Immediately place the lid on the cup and place the cup anywhere on the wire rack in the Heated Landing Shelf.

**WARNING: DO NOT** place any object under the cup (paper, plastic, foil, cardboard, etc...) to help "balance the cup" on the rack.

After 10 minutes, place the cup on the counter, immediately insert thermometer end (or needle probe) thru a small (1/4" max) hole in the lid, and record the temperature of the water. If the temperature is between 140°-150°F (60°-65° C) the unit is operating as intended. If the temperature of the Heated Landing Shelf is too high or too low it can be adjusted by turning the adjustment potentiometer located behind the access door on the control panel.

**NOTE: On STB-11 & STB-22** To raise the access door, loosen the screw between the two heater pots, then raise the door to expose the adjustment potentiometers.

**On STB-36 & STB-48** Loosen the screw to the right of the temperature controls and slide it to the right exposing the adjustment potentiometers.

Turning the pot clockwise will adjust the temperature up, turning it counter clockwise will adjust it down. Each small mark will cause about a 5 degree adjustment in temperature.

## STB-36BF SERIES WIRING DIAGRAM

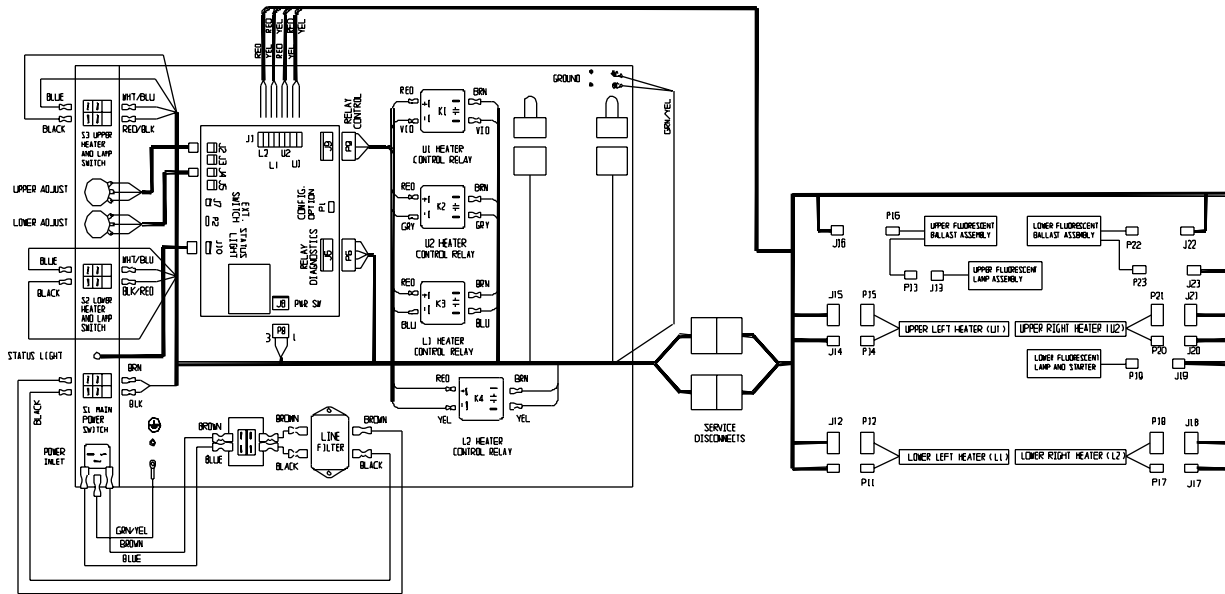

## STB-48BF SERIES WIRING DIAGRAM

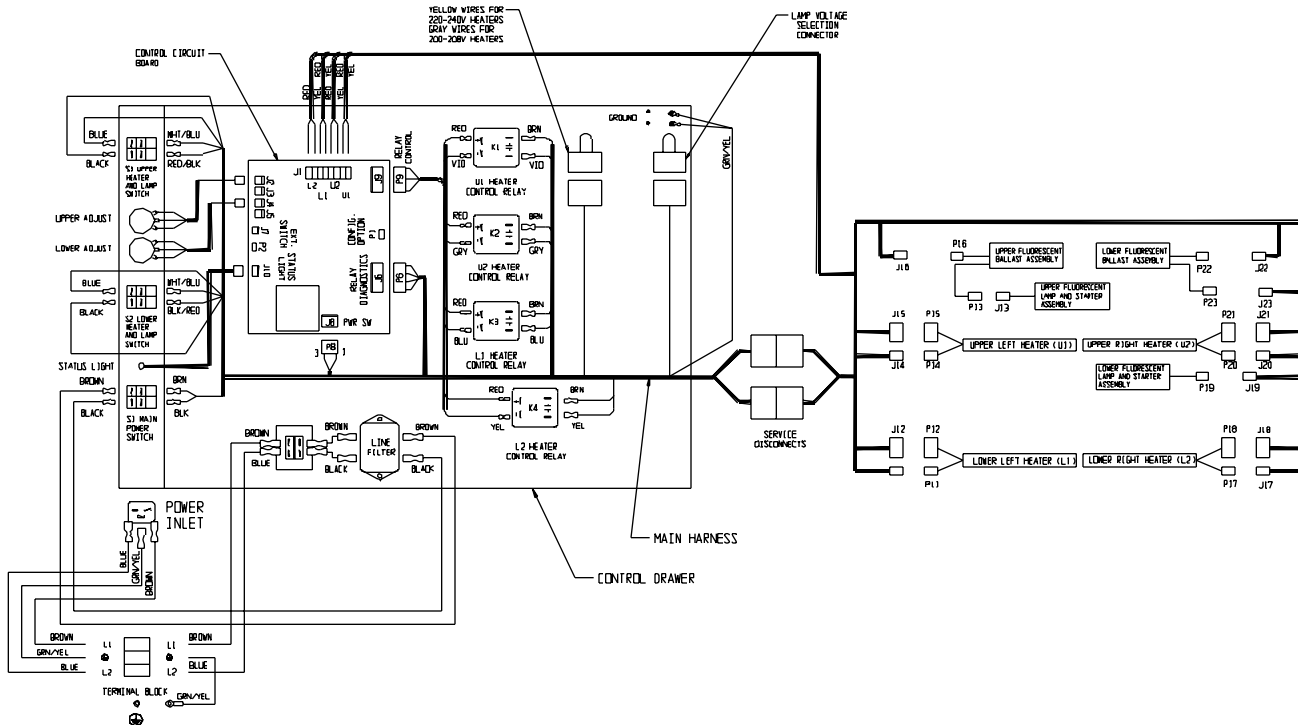

# WIRING DIAGRAM AND INSTALLATION MODELS STB-36AFJ ONLY

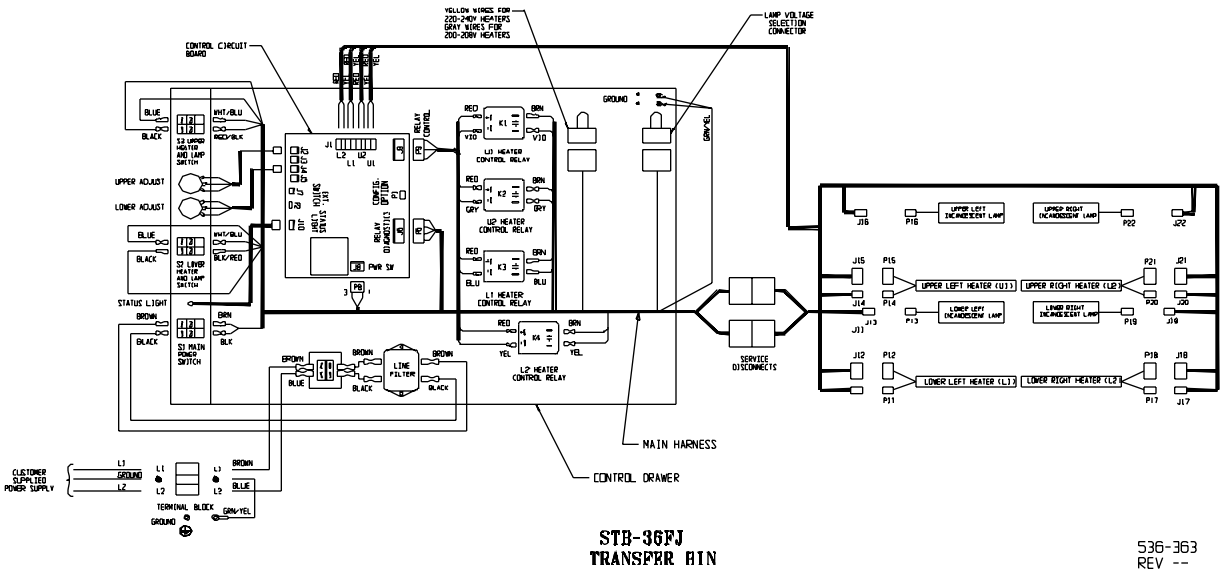

**TO HARD WIRE UNIT REMOVE THE UPPER COVER EXPOSING THE CONTROL DRAWER. FOLLOW THE INSTRUCTIONS BELOW USING THE WIRING DIAGRAM ABOVE.**

