



operator manual

InstaCut 3.5 & 3.5W

This document includes:

- Safety Notices
- Specifications
- Installation Instructions
- Operating Instructions
- Cleaning Instructions
- Warranty Statement

P/N: 2803054
Revision: E



3.5W shown with optional accessories



Lincoln Foodservice Products, LLC
1111 North Hadley Road
Fort Wayne, Indiana 46804
United States of America
Technical Support Hotline: (800) 678-9511
Telephone: (260) 459-8200
www.lincolnsmallwares.com

WARNING AND SAFETY INFORMATION

**WARNING:**

This machine contains sharp blades and can cause serious injury or death if not handled properly. All operators of this equipment should read this operator manual before operating equipment.

**CAUTION:**

In order to avoid damage to people and the appliance, read and follow the manufacturer's instructions for the cleaning of this equipment.

LIMITED TWO (2) YEAR WARRANTY

Lincoln Foodservice Products, LLC ("Lincoln") warrants, to the original purchaser for use in the United States of America, that each new item of Redco food preparation utensils (other than blades) manufactured by it ("Warranted Product") is free of defects in material and workmanship under normal use and conditions.

The exclusive remedy available under this Limited Warranty is that Lincoln will, free of charge, but at its option, subject to, and in accordance with the terms and conditions of this Limited Warranty, repair or replace, for the original purchaser for use in the United States of America, any Warranted Products or part thereof that proves to be defective with the same or a similar item or part, it is returned to Lincoln in accordance with the procedure set out on the warranty card.

This Limited Warranty applies only to original parts of Warranted Products sold for use in the United States of America and does not apply to any Warranted Products located outside the United States of America, regardless of where sold, or to any item or part thereof that has been subjected to accident, casualty, alteration, misuse, or abuse or if the date of manufacture is altered or removed.

THIS LIMITED WARRANTY DOES NOT APPLY TO BLADES WHICH ARE SOLD COMPLETELY WITHOUT WARRANTY OR GUARANTEE OF ANY KIND, EXPRESSED OR IMPLIED. THE OBLIGATION OF LINCOLN IS LIMITED TO THE ABOVE AND, EXCEPT AS EXPRESSLY STATED HEREIN, LINCOLN MAKES NO GUARANTEES OR WARRANTIES, EXPRESSED OR IMPLIED, INCLUDING WITHOUT LIMITATION, WARRANTIES OF FITNESS OR MERCHANTABILITY, WITH RESPECT TO WARRANTED PRODUCTS. LINCOLN SHALL NOT BE LIABLE FOR SPECIAL, INCIDENTAL, OR CONSEQUENTIAL DAMAGES OF ANY KIND. NO ONE IS AUTHORIZED TO MAKE ANY GUARANTEES OR WARRANTIES, EXPRESSED OR IMPLIED, ON BEHALF OF LINCOLN.

SOME STATES DO NOT ALLOW LIMITATIONS OF IMPLIED WARRANTIES, OR THE EXCLUSION OR LIMITATION OF INCIDENTAL OR CONSEQUENTIAL DAMAGES IN CONNECTION WITH THE SALE OF CONSUMER PRODUCTS, CONSEQUENTLY, IF YOU ARE A CONSUMER, AS THAT TERM IS LEGALLY DEFINED, THE ABOVE LIMITATION OR EXCLUSION MAY NOT APPLY TO YOU.

UNIT DESCRIPTIONS

INSTACUT 3.5 (TABLETOP UNIT)	
CATALOG #	DESCRIPTION
15000	INSTACUT 3.5 TABLETOP, 1/4" DICE
15001	INSTACUT 3.5 TABLETOP, 3/8" DICE
15002	INSTACUT 3.5 TABLETOP, 1/2" DICE
15003	INSTACUT 3.5 TABLETOP, 4 SECTION WEDGE
15005	INSTACUT 3.5 TABLETOP, 6 SECTION WEDGE
15006	INSTACUT 3.5 TABLETOP, 8 SECTION WEDGE
15007	INSTACUT 3.5 TABLETOP, 10 SECTION WEDGE
15008	INSTACUT 3.5 TABLETOP, 12 SECTION WEDGE
15009	INSTACUT 3.5 TABLETOP, 6 SECTION CORE
15010	INSTACUT 3.5 TABLETOP, 8 SECTION CORE

INSTACUT 3.5 (WALL-MOUNTED UNIT)	
CATALOG #	DESCRIPTION
15016	INSTACUT 3.5 WALLMOUNT, 1/4" DICE
15017	INSTACUT 3.5 WALLMOUNT, 3/8" DICE
15018	INSTACUT 3.5 WALLMOUNT, 1/2" DICE
15019	INSTACUT 3.5 WALLMOUNT, 4 SECTION WEDGE
15021	INSTACUT 3.5 WALLMOUNT, 6 SECTION WEDGE
15022	INSTACUT 3.5 WALLMOUNT, 8 SECTION WEDGE
15023	INSTACUT 3.5 WALLMOUNT, 10 SECTION WEDGE
15024	INSTACUT 3.5 WALLMOUNT, 12 SECTION WEDGE
15026	INSTACUT 3.5 WALLMOUNT, 8 SECTION CORE



WARNING:

It is imperative that a wall-mounted unit be installed securely to wall studs to insure proper operation and employee safety. Improperly installed units can result in employee injury and structural damage.



CAUTION:

InstaCut 3.5 Wall-Mounted units are designed to accept 1/4" diameter mounting hardware. Be sure to use 1/4" diameter mounting hardware when attaching to wall studs to provide for a secure installation.



CAUTION:

Prior to using your new equipment, or when replacing blade assemblies, it is important to clean the unit. Wash new blades with warm, soapy water and rinse thoroughly to remove the thin protective oil film. Let air dry.



CAUTION:



Blades are sharp and can cause injury. Check machine before using to insure machine is clean. Check for broken, nicked or dull blades and if found, replace blade assembly. Check to insure that the pusher head sits down completely on the rubber bumpers. The suction cups on each rear leg will hold the unit securely to smooth surfaces. If necessary, lubricate guide rods using a light coating of mineral oil, Petro Gel, or food grade lubricant. **DO NOT USE COOKING OIL AS IT WILL BECOME STICKY AND MAY PERMANENTLY DAMAGE THE PUSHER HEAD BEARINGS.**

OPERATING INSTRUCTIONS

1. Check machine before using to ensure unit is clean. Check for broken, nicked or dull blades and if found, replace blade assembly. Check to insure that the pusher head sits down completely on the rubber bumpers. With tabletop units, the suction cups on each rear leg will hold the unit securely to smooth surfaces. To remove, push unit to the rear while releasing suction on legs.
2. Prepare the produce to be diced by cutting to your specifications. Maximum size of produce that will go through the dicer, wedger, and corer is approximately 3 1/2" across.
3. Place hand on the handle, lift the pusher head and place product on the blades, flat side down.
4. Remove hand and fingers from cutting area, place that hand on dicer leg, leave the other hand on the T-Handle. Then, with a strong, quick, downward thrust, force the produce through the blades.
5. If the pusher head does not slide freely on the guide rods, lubricate with mineral oil or Petro Gel. Never use cooking oil as it will cause the unit to become sticky!

CLEANING INSTRUCTIONS

To insure optimal performance of the equipment, clean the machine after every use. Food acids corrode the cutting blades, ruining the cutting edges and reducing the cutting blade life.

Refer to the illustration for additional assistance in reviewing the following cleaning instructions.

1. Lift the pusher head assembly off the guide rods.
2. Raise bumpers approximately 2 inches.
3. Loosen thumbscrew.
4. Remove the cutting blade assembly by pressing upwards on the bottom side of the blade holder, where the thumb-screw is located.
5. Thoroughly wash the push block guide, the pusher head, and the frame.
6. The cutting blade assembly is best cleaned by forcing water under pressure through the blades from the unsharpened side. If necessary, use a nylon bristle cleaning brush to push food particles out from the unsharpened side of the cutting blade assembly.



CAUTION: Blades are sharp and can cause injury. Never use machine unless all four rubber feet are in place.

7. Replace the cutting blade assembly by inserting the tab on the blade holder into the groove in the base, then lowering the blade holder into the seated position in the base. Be sure blade holder is seated flush in the base. Tighten thumbscrew.



CAUTION: Push only the plastic blade holder. Sharp edges of the cutting blades are pointed upward and could cause serious injury.

8. Slide bumpers down guide rods to contact base. Position pusher head assembly onto vertical guide rods, slowly lower pusher head assembly and check pusher head block to blade alignment.

REPLACING BLADE ASSEMBLY



CAUTION: Blades are sharp and can cause injury. Never use machine unless all four rubber feet are in place.

1. Lift pusher head assembly off the guide rods.
2. Raise bumpers approximately two inches above base. (Refer to illustration for more information.)
3. Loosen thumbscrew.
4. Remove cutting blade assembly by pressing upwards on the bottom side of the blade holder, where the thumb-screw is located.
5. When replacing blade sets, remove cutting blade assembly as described above and follow instructions 6 through 8.



CAUTION: Keep the sharp blade edges away from hands when handling the machine.

6. Wash new cutting blade assembly with warm soapy water to remove protective oil film, rinse thoroughly and air dry.
7. Install the new cutting blade assembly by inserting the tab on the blade holder into the groove in the base, then lowering the front side of the blade holder into the seated position on the base. Be sure the blade holder is seated flush in the base. Tighten thumbscrew.
8. Slide bumpers down guide rods to contact base. Position pusher head assembly onto vertical guide rods, slowly lower pusher head assembly, and check pusher head block to blade alignment.

SPARE PARTS LIST - INSTACUT 3.5

LETTER	PART #	DESCRIPTION
A	071	Screw, Hex Head Stainless
B	2319	Black Rubber Foot, Screw On (sold individually)
C	379001	Base (includes Guide Rods)
D	379005	Pusher Head Casting (includes Bearings)
E	379007	Pusher Head Block, 3/8" Cut
	379008	Pusher Head Block, 1/4" & 1/2" Cut
F	379009	Bumper
G	379015	Suction Foot
H	379031	Guide Rod, 3/8" Diameter
I	379034	Thumbscrew, 1/4-20 x .875" (before 8/2008)
	2014004	Thumbscrew, 1/4-20 x 1.0" (after 8/2008)
J	379038	Pusher Head for 4-8 Section Wedger
	379039	Pusher Head for 6-12 Section Wedger
	379040	Pusher Head for 5-10 Section Wedger
	379041	Pusher Head for 4-8 Section Corer
	379061	Pusher Head for 6-12 Section Corer

LETTER	PART #	DESCRIPTION
K	353	Lock Nut 5/16" x 18 UNC
L	379034	Thumbscrew, 1/4-20 x .875" (before 8/2008)
	371090	Thumbscrew, 1/4-20 x .750" (after 8/2008)
M	15065	Blade, 4 Section Wedge
	15067	Blade, 6 Section Wedge
	15068	Blade, 8 Section Wedge
	15069	Blade, 10 Section Wedge
	15070	Blade, 12 Section Wedge
	15071	Blade, 6 Section Corer
	15072	Blade, 8 Section Corer
N	15062	1/4" Dice
	15063	3/8" Dice
	15064	1/2" Dice
	15086	1/4" & 1/2" Dice

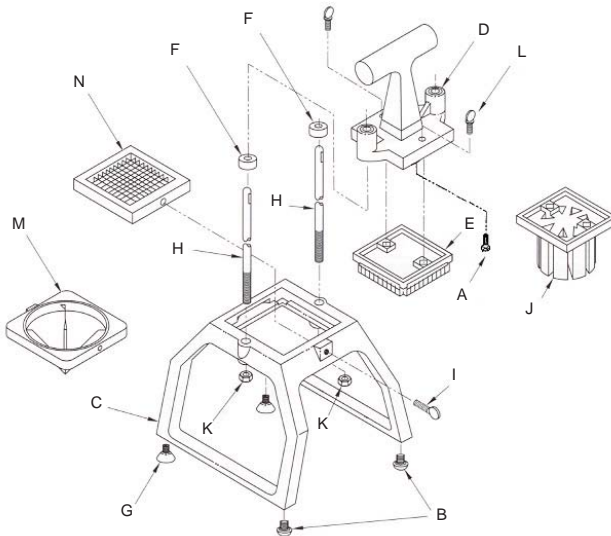

SPARE PARTS LIST - INSTACUT 3.5 (WALL MOUNTED)

LETTER	PART #	DESCRIPTION
A	353	Lock Nut
B	4411	Pull Pin w/ Ring 1 1/4" Long
C	379007	Pusher Head Block, 3/8"
	379008	Pusher Head Block, 1/4" & 1/2"
D	379009	Rubber Bumper, 3/8" I.D.
E	379033	Blade Holder
F	379025	Screw, Shoulder
G	379027	Handle Link
H	379030	Base
I	379031	Guide Rod
J	379032	Pusher Head Casting w/ Bearings
K	379034	Thumbscrew 1/4-20 x .875" (before 8/2008)
	371090	Thumbscrew 1/4-20 x .750" (after 8/2008)
L	379038	Pusher Head 4-8 Section Wedger
	379039	Pusher Head 6-12 Section Wedger
	379040	Pusher Head 5-10 Section Wedger
	379041	Pusher Head 4-8 Section Corer
	379061	Pusher Head 6 Section Corer

LETTER	PART #	DESCRIPTION	
M	379046	Nutblock, Hex	
N	379052	D-Handle, Rubber Coated	
O	15073	Blade, 4 Section Wedge	
	15074	Blade, 5 Section Wedge	
	15075	Blade, 6 Section Wedge	
	15076	Blade, 8 Section Wedge	
	15077	Blade, 10 Section Wedge	
	15078	Blade, 12 Section Wedge	
	15079	Blade, 6 Section Core	
	15080	Blade, 8 Section Core	
	P	15081	1/4" Dice
		15082	3/8" Dice
15083		1/2" Dice	
15084		1/4" x 1/2" Dice	
Not Shown	379006	Screw, 1/4-20 x 1" Long	
Not Shown	379016	Screw 6-32	
Not Shown	379045	Shoulder Slot Screw	

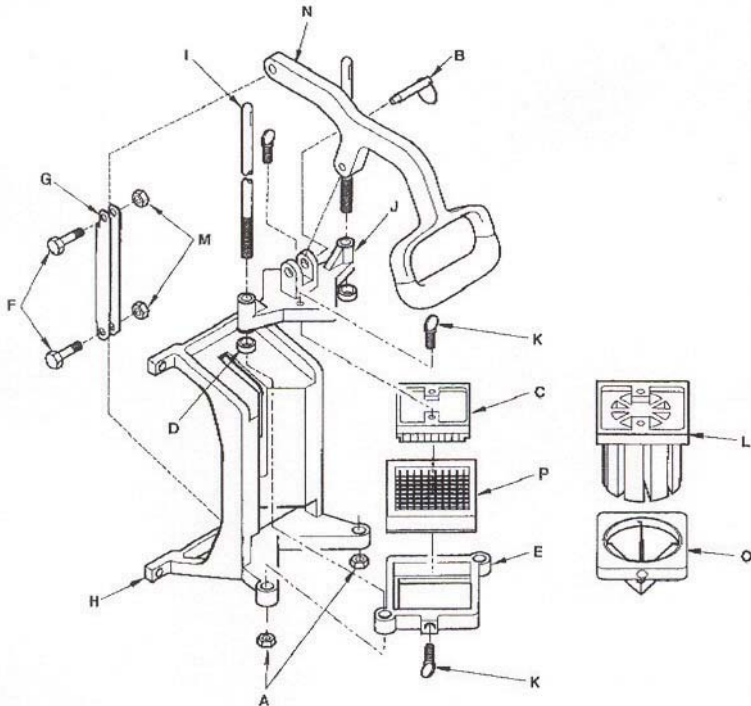

This page intentionally left blank.

