



|

FLAV-R-FRESH[®]

Display Cabinets

FDW Series

FDW-1

FDW-2

FDW-1X

FDW-2X

**REPLACEMENT
PARTS LIST**

HATCO FLAV-R-FRESH FDW SERIES DISPLAY CABINETS

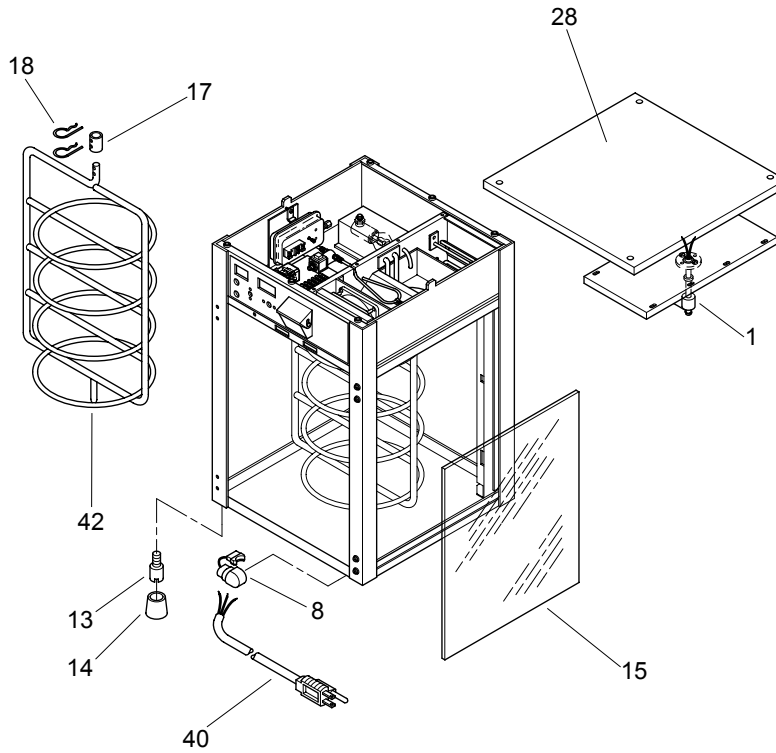
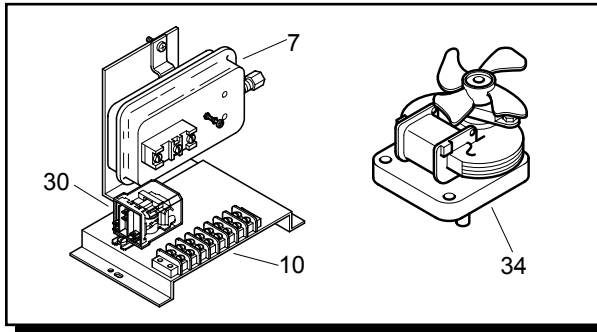
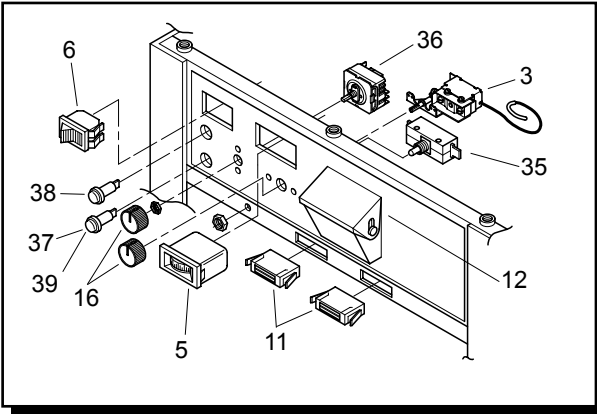

Model Designation

FDW-XX

- F = Flav-R
- D = Display
- W = Warmer
- X = Number of doors
- X = No rotating rack motor

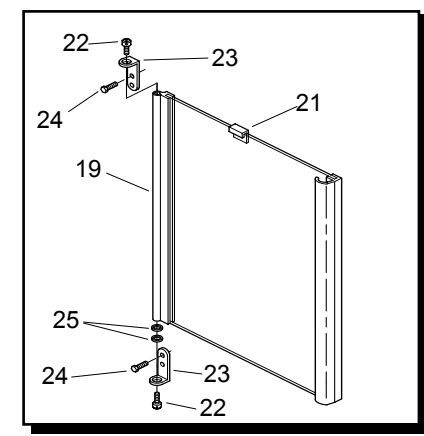
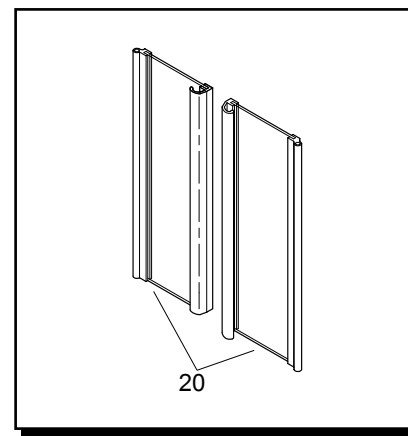
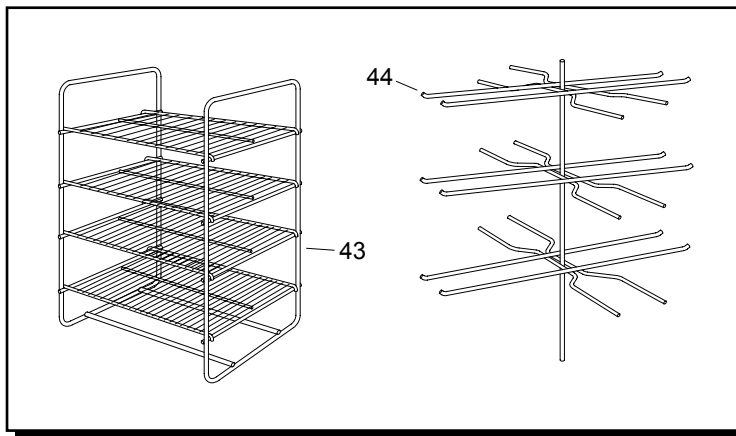
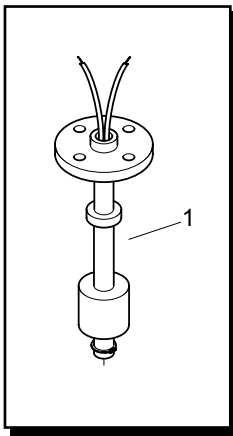
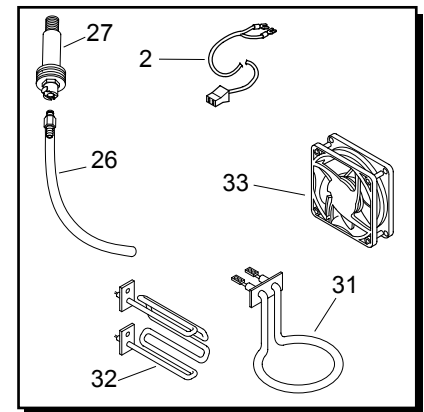
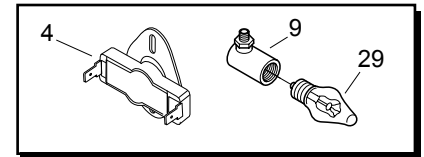

PARTS COMMON TO ALL FDW MODELS

ITEM	DESCRIPTION	PART NO.	QTY.	ITEM	DESCRIPTION	PART NO.	QTY.
1	Float Switch	R02.01.029.00	1	16	Knob	05.30.019.00	2
2	Blower Motor Cord	02.12.001A.00	1	17	Rack Coupler with Pins	R04.17.078.00	1
3	Air Temp. Thermostat	02.16.002.00	1	18	Cotter Pins	05.04.352.00	2
4	High Limit Disk	R02.16.118.00	1	19	Door Assembly	R04.24.022.00	1-2
5	Temperature Display	02.16.050.00	1	20	French Door (2 per set)	R04.24.021.00	1-2 Sets
6	On/Off Rocker Switch	02.19.015.00	1	21	Striker Plate	05.30.027.00	1-4
*7	Air Flow Switch	02.19.050.00	1	22	Hinge Pin	04.24.023.00	2/Door
8	Cord Grip (Power Cord)	02.20.206.00	1	23	Hinge	04.24.020.00	2/Door
9	Light Socket	02.30.039.00	1	24	Hinge Mounting Screw		
10	Terminal Block (8 pole)	02.15.012.00	1		8/32 x 1/2" Hex Head	05.04.099.00	4/Door
11	Door Magnet	05.30.026.00	2-4	25	Nylon Washer	05.11.033.00	3/Door
12	Fill Cup with Cover	R05.30.050.00	1	+26	Plastic Drain Tube	R03.40.054.00	1
13	Metal Foot	05.04.087.00	4	+27	Ceiling Drain	R03.40.055.00	1
14	Rubber Cover, Foot	05.06.038.00	4	28	Top Cover - Painted	04.24.004.00	1
15	Glass (Side & Rear)	04.40.025.00	3				

* Item 7 not used on units built after July 15, 1996.

+ Items 26 & 27 used with s/n 5143899510 and later.

PARTS SPECIFIC TO MODEL FDW-1

ITEM	DESCRIPTION	100V 60 Hz	120V 60 Hz	120V Canada	208V 60 Hz	220V 50 Hz	240V 50 Hz	220-230V CE 50 Hz	230-240V CE 50 Hz
29	Light Bulb	02.30.043.00	02.30.043.00	02.30.043.00	---	02.30.058.00	02.30.058.00	02.30.058.00	02.30.058.00
30	Relay	02.01.187.00	02.01.028.00	02.01.028.00	---	02.01.043.00	02.01.043.00	02.01.043.00	02.01.043.00
31	Water Heating Element (325W)	R02.05.512.00	R02.05.006.00	R02.05.006.00	---	R02.05.016.00	R02.05.013.00	R02.05.016.00	R02.05.013.00
32	Air Heating Element (1050W)	R02.05.511.00	R02.05.011.00	R02.05.011.00	---	R02.05.015.00	R02.05.012.00	R02.05.015.00	R02.05.012.00
33	Blower Motor	02.12.001.00	02.12.001.00	02.12.001.00	---	02.12.006.00	02.12.006.00	02.12.006.00	02.12.006.00
34	Rack Motor	02.12.004.00	02.12.004.00	02.12.004.00	---	02.12.026.00	02.12.026.00	02.12.026.00	02.12.026.00
35	Door Switch (Qty. 1)	R02.19.004.00	R02.19.004.00	R02.19.004.00	---	R02.19.004.00	R02.19.004.00	R02.19.004.00	R02.19.004.00
36	Humidity Control	R02.19.160.00	R02.19.018.00	R02.19.018.00	---	R02.19.019.00	R02.19.019.00	R02.19.019.00	R02.19.019.00
37	Indicator Light-Red	02.19.154.00	02.19.154.00	02.19.154.00	---	02.19.151.00	02.19.151.00	---	---
38	Indicator Light-Green	02.19.155.00	02.19.155.00	02.19.155.00	---	02.19.150.00	02.19.150.00	02.19.150.00	02.19.150.00
39	Indicator Light-Yellow	---	---	---	---	---	---	02.19.152.00	02.19.152.00
40	Power Cord	02.18.035.00	02.18.035.00	02.18.082.00	---	02.18.109.00	02.18.120.00	02.18.120.00	02.18.120.00
41	Terminal Block (3 pole) (not shown)	---	---	---	---	---	---	02.15.030.00	02.15.030.00
42	4-Tier Circle Rack	04.24.025.00	04.24.025.00	04.24.025.00	---	04.24.025.00	04.24.025.00	04.24.025.00	04.24.025.00
43	4-Shelf Multi-Purpose Rack	R04.17.016.00	R04.17.016.00	R04.17.016.00	---	R04.17.016.00	R04.17.016.00	R04.17.016.00	R04.17.016.00
44	3-Tier Pretzel Rack	04.17.079.00	04.17.079.00	04.17.079.00	---	04.17.079.00	04.17.079.00	04.17.079.00	04.17.079.00
	Electrical Drawing	HS2-5851	HS2-743	HS2-743	---	HS1-3218	HS1-2333	HS1-4405	HS1-4406

Shaded area reflects **export models only**.

Model FDW-1 **cannot** be field converted to model FDW-2.

PARTS SPECIFIC TO MODEL FDW-1X									
ITEM	DESCRIPTION	100V 60 Hz	120V 60 Hz	120V Canada	208V 60 Hz	220V 50 Hz	240V 50 Hz	220-230V CE 50 Hz	230-240V CE 50 Hz
29	Light Bulb	02.30.043.00	02.30.043.00	02.30.043.00	---	02.30.058.00	02.30.058.00	02.30.058.00	02.30.058.00
30	Relay	02.01.187.00	02.01.028.00	02.01.028.00	---	02.01.043.00	02.01.043.00	02.01.043.00	02.01.043.00
31	Water Heating Element (325W)	R02.05.512.00	R02.05.006.00	R02.05.006.00	---	R02.05.016.00	R02.05.013.00	R02.05.016.00	R02.05.013.00
32	Air Heating Element (1050W)	R02.05.511.00	R02.05.011.00	R02.05.011.00	---	R02.05.015.00	R02.05.012.00	R02.05.015.00	R02.05.012.00
33	Blower Motor	02.12.001.00	02.12.001.00	02.12.001.00	---	02.12.006.00	02.12.006.00	02.12.006.00	02.12.006.00
34	Rack Motor	---	---	---	---	---	---	---	---
35	Door Switch	---	---	---	---	---	---	---	---
36	Humidity Control	R02.19.160.00	R02.19.018.00	R02.19.018.00	---	R02.19.019.00	R02.19.019.00	R02.19.019.00	R02.19.019.00
37	Indicator Light-Red	02.19.154.00	02.19.154.00	02.19.154.00	---	02.19.151.00	02.19.151.00	---	---
38	Indicator Light-Green	02.19.155.00	02.19.155.00	02.19.155.00	---	02.19.150.00	02.19.150.00	02.19.150.00	02.19.150.00
39	Indicator Light-Yellow	---	---	---	---	---	---	02.19.152.00	02.19.152.00
40	Power Cord	02.18.035.00	02.18.035.00	02.18.082.00	---	02.18.109.00	02.18.120.00	02.18.109.00	02.18.120.00
41	Terminal Block (3 pole) (not shown)	---	---	---	---	---	---	02.15.030.00	02.15.030.00
42	4-Tier Circle Rack	---	---	---	---	---	---	---	---
43	4-Shelf Multi-Purpose Rack	R04.17.016.00	R04.17.016.00	R04.17.016.00	---	R04.17.016.00	R04.17.016.00	R04.17.016.00	R04.17.016.00
44	3-Tier Pretzel Rack	---	---	---	---	---	---	---	---
	Electrical Drawing	HS2-5851	HS2-743	HS2-743	---	HS1-3218	HS1-2333	HS1-4405	HS1-4406

Shaded area reflects **export models only**.

PARTS SPECIFIC TO MODEL FDW-2

ITEM	DESCRIPTION	100V 60 Hz	120V 60 Hz	120V Canada	208V 60 Hz	220V 50 Hz	240V 50 Hz	220-230V CE 50 Hz	230-240V CE 50 Hz
29	Light Bulb	02.30.043.00	02.30.043.00	02.30.043.00	---	02.30.058.00	02.30.058.00	02.30.058.00	02.30.058.00
30	Relay	02.01.187.00	02.01.028.00	02.01.028.00	---	02.01.043.00	02.01.043.00	02.01.043.00	02.01.043.00
31	Water Heating Element (325W)	R02.05.512.00	R02.05.006.00	R02.05.006.00	---	R02.05.016.00	R02.05.013.00	R02.05.016.00	R02.05.013.00
32	Air Heating Element (1050W)	R02.05.511.00	R02.05.011.00	R02.05.011.00	---	R02.05.015.00	R02.05.012.00	R02.05.015.00	R02.05.012.00
33	Blower Motor	02.12.001.00	02.12.001.00	02.12.001.00	---	02.12.006.00	02.12.006.00	02.12.006.00	02.12.006.00
34	Rack Motor	02.12.004.00	02.12.004.00	02.12.004.00	---	02.12.026.00	02.12.026.00	02.12.026.00	02.12.026.00
35	Door Switch (Qty. 2)	R02.19.004.00	R02.19.004.00	R02.19.004.00	---	R02.19.004.00	R02.19.004.00	R02.19.004.00	R02.19.004.00
36	Humidity Control	R02.19.160.00	R02.19.018.00	R02.19.018.00	---	R02.19.019.00	R02.19.019.00	R02.19.019.00	R02.19.019.00
37	Indicator Light-Red	02.19.154.00	02.19.154.00	02.19.154.00	---	02.19.151.00	02.19.151.00	---	---
38	Indicator Light-Green	02.19.155.00	02.19.155.00	02.19.155.00	---	02.19.150.00	02.19.150.00	02.19.150.00	02.19.150.00
39	Indicator Light-Yellow	---	---	---	---	---	---	02.19.152.00	02.19.152.00
40	Power Cord	02.18.035.00	02.18.035.00	02.18.082.00	---	02.18.109.00	02.18.120.00	02.18.109.00	02.18.120.00
41	Terminal Block (3 pole) (not shown)	---	---	---	---	---	---	02.15.030.00	02.15.030.00
42	4-Tier Circle Rack	04.24.025.00	04.24.025.00	04.24.025.00	---	04.24.025.00	04.24.025.00	04.24.025.00	04.24.025.00
43	4-Shelf Multi-Purpose Rack	R04.17.016.00	R04.17.016.00	R04.17.016.00	---	R04.17.016.00	R04.17.016.00	R04.17.016.00	R04.17.016.00
44	3-Tier Pretzel Rack	04.17.079.00	04.17.079.00	04.17.079.00	---	04.17.079.00	04.17.079.00	04.17.079.00	04.17.079.00
	Electrical Drawing	HS2-5851	HS2-743	HS2-743	---	HS1-3218	HS1-2333	HS1-4405	HS1-4406

Shaded area reflects **export models only**.

PARTS SPECIFIC TO MODEL FDW-2X

ITEM	DESCRIPTION	100V 60 Hz	120V 60 Hz	120V Canada	208V 60 Hz	220V 50 Hz	240V 50 Hz	220-230V CE 50 Hz	230-240V CE 50 Hz
29	Light Bulb	02.30.043.00	02.30.043.00	02.30.043.00	---	02.30.058.00	02.30.058.00	02.30.058.00	02.30.058.00
30	Relay	02.01.187.00	02.01.028.00	02.01.028.00	---	02.01.043.00	02.01.043.00	02.01.043.00	02.01.043.00
31	Water Heating Element (325W)	R02.05.512.00	R02.05.006.00	R02.05.006.00	---	R02.05.016.00	R02.05.013.00	R02.05.016.00	R02.05.013.00
32	Air Heating Element (1050W)	R02.05.511.00	R02.05.011.00	R02.05.011.00	---	R02.05.015.00	R02.05.012.00	R02.05.015.00	R02.05.012.00
33	Blower Motor	02.12.001.00	02.12.001.00	02.12.001.00	---	02.12.006.00	02.12.006.00	02.12.006.00	02.12.006.00
34	Rack Motor	---	---	---	---	---	---	---	---
35	Door Switch	---	---	---	---	---	---	---	---
36	Humidity Control	R02.19.160.00	R02.19.018.00	R02.19.018.00	---	R02.19.019.00	R02.19.019.00	R02.19.019.00	R02.19.019.00
37	Indicator Light-Red	02.19.154.00	02.19.154.00	02.19.154.00	---	02.19.151.00	02.19.151.00	---	---
38	Indicator Light-Green	02.19.155.00	02.19.155.00	02.19.155.00	---	02.19.150.00	02.19.150.00	02.19.150.00	02.19.150.00
39	Indicator Light-Yellow	---	---	---	---	---	---	02.19.152.00	02.19.152.00
40	Power Cord	02.18.035.00	02.18.035.00	02.18.082.00	---	02.18.109.00	02.18.120.00	02.18.109.00	02.18.120.00
41	Terminal Block (3 pole) (not shown)	---	---	---	---	---	---	02.15.030.00	02.15.030.00
42	4-Tier Circle Rack	---	---	---	---	---	---	---	---
43	4-Shelf Multi-Purpose Rack	R04.17.016.00	R04.17.016.00	R04.17.016.00	---	R04.17.016.00	R04.17.016.00	R04.17.016.00	R04.17.016.00
44	3-Tier Pretzel Rack	---	---	---	---	---	---	---	---
	Electrical Drawing	HS2-5851	HS2-743	HS2-743	---	HS1-3218	HS1-2333	HS1-4405	HS1-4406

Shaded area reflects **export models only**.

HATCO AUTHORIZED PARTS DISTRIBUTORS

ALABAMA

Jones McLeod Appl. Svc.
Birmingham 205-251-0159

ARIZONA

Auth. Comm. Food Equip.
Phoenix 602-234-2443
Byassee Equipment Co.
Phoenix 602-252-0402

CALIFORNIA

Industrial Electric
Huntington Beach 714-379-7100
Chapman Appl. Service
San Diego 619-298-7106
P & D Appliance
S. San Francisco 650-635-1900

COLORADO

Hawkins Commercial Appliance
Englewood 303-781-5548

DELAWARE

Food Equipment Service
Wilmington 302-996-9363

FLORIDA

Whaley Foodservice Repair
Jacksonville 904-725-7800
Nass Service Co., Inc.
Orlando 407-425-2681
B.G.S.I.
Pompano Beach 954-971-0456
Comm. Appliance Service
Tampa 813-663-0313

GEORGIA

Southeastern Rest. Svc.
Norcross 770-446-6177

HAWAII

Burney's Comm. Service, Inc.
Honolulu 808-848-1466
Food Equip Parts & Service
Honolulu 808-847-4871

ILLINOIS

Parts Town
Lombard 708-865-7278
Eichenauer Elec. Service
Decatur 217-429-4229
Midwest Elec. Appl. Service
Elmhurst 630-279-8000
Cone's Repair Service
Moline 309-797-5323

INDIANA

GCS Service
Indianapolis 317-545-9655

IOWA

Electric Motor Service Co.
Davenport 319-323-1823

KENTUCKY

GCS Service
Louisville 502-367-1788

LOUISIANA

Chandlers Parts & Service
Baton Rouge 225-272-6620
Bana Comm. Parts, Inc.
Shreveport 318-631-6550

MARYLAND

Electric Motor Service
Baltimore 410-467-8080
GCS Service
Silver Spring 301-585-7550

MASSACHUSETTS

Ace Service Co., Inc.
Needham 781-449-4220

MICHIGAN

Commercial Kitchen Service
Bay City 517-893-4561
Bildons Appliance Service
Detroit 248-478-3320
Midwest Food Equip. Service
Grandville 616-261-2000

MINNESOTA

GCS Service
Minneapolis 612-546-4221

MISSOURI

GCS Service
Kansas City 816-920-5999
Commercial Kitchen Services
St. Louis 314-890-0700
Kaemmerlen Parts & Service
St. Louis 314-535-2222

NEBRASKA

Anderson Electric
Omaha 402-341-1414

NEVADA

Burney's Commercial
Las Vegas 702-736-0006
Hi. Tech Commercial Service
N. Las Vegas 702-649-4616

NEW JERSEY

Jay Hill Repair
Fairfield 973-575-9145
Service Plus
Flanders 973-691-6300

NEW YORK

Acme American Repairs, Inc.
Brooklyn 718-456-6544
Alpro Service Co.
Brooklyn 718-386-2515
Appliance Installation
Buffalo 716-884-7425
Northern Parts Dist.
Plattsburgh 518-563-3200
J. B. Brady, Inc.
Syracuse 315-422-9271

NORTH CAROLINA

Authorized Appliance
Charlotte 704-377-4501

OHIO

Akron/Canton Comm. Svc. Inc.
Akron 330-753-6635
Certified Service Center
Cincinnati 513-772-6600
GCS Service
Columbus 614-476-3225
Electrical Appl. Repair Service
Independence 216-459-8700
E. A. Wichman Co.
Toledo 419-385-9121

OKLAHOMA

Hagar Rest. Service, Inc.
Oklahoma City 405-235-2184
Krueger, Inc.
Oklahoma City 405-528-8883

OREGON

Bressie Electric Co.
Portland 503-231-7171
Ron's Service, Inc.
Portland 503-624-0890

PENNSYLVANIA

Authorized Factory Service
Coraopolis 412-262-2330
FAST Comm. Appl. Service
Philadelphia 215-288-4800
GCS Service
Pittsburgh 412-787-1970
K & D Service Co.
Harrisburg 717-236-9039
Elmer Schultz Services
Philadelphia 215-627-5401
Electric Repair Co.
Reading 610-376-5444

RHODE ISLAND

Marshall Electric Co.
Providence 401-331-1163

SOUTH CAROLINA

Whaley Foodservice Repair
W. Columbia 803-791-4420

TENNESSEE

Camp Electric
Memphis 901-527-7543

TEXAS

Stove Parts Supply
Fort Worth 817-831-0381
Armstrong Repair Service
Houston 713-666-7100
Commercial Kitchen Repair Co.
San Antonio 210-735-2811
San Antonio Rest. Equip.
San Antonio 210-532-1660

UTAH

GCS Service
Salt Lake City 801-487-3653

VIRGINIA

Daubers
Norfolk 757-855-4097
Daubers
Springfield 703-866-3600

WASHINGTON

Restaurant Appl. Service
Seattle 206-524-8200

WISCONSIN

A.S.C., Inc.
Madison 608-246-3160
A.S.C., Inc.
Milwaukee 414-543-6460

CANADA

BRITISH COLUMBIA

Key Food Equipment Service
Vancouver 604-433-4484

ONTARIO

R.G. Henderson Ltd.
Toronto 416-422-5580

HATCO CORPORATION

P.O. Box 340500, Milwaukee, WI 53234-0500 U.S.A.

(800) 558-0607 (414) 671-6350

Parts & Service Fax (800) 690-2966 Int'l. Fax (414) 671-3976

www.hatcocorp.com
