

Lang



Service Manual for the Lang Models:

C-28, F-28

TABLE OF CONTENTS

<u>CHAPTER</u>	<u>PAGE</u>
1. TABLE OF CONTENTS.....	1
2. READ FIRST	2
3. EQUIPMENT DESCRIPTION.....	4
4. INSTALLATION	5
5. START-UP.....	6
6. GENERAL OPERATION	7
7. SEQUENCE OF OPERATION.....	8
8. TROUBLESHOOTING.....	9
9. TECHNICAL DATA.....	10
10. WIRING DIAGRAMS	11
11. PARTS LIST	13

CAUTION: EACH UNIT IS HEAVY. FOR SAFE HANDLING, INSTALLER SHOULD OBTAIN HELP AS NEEDED, OR EMPLOY APPROPRIATE MATERIALS HANDLING EQUIPMENT (SUCH AS A FORKLIFT, DOLLY, OR PALLET JACK) TO REMOVE THE UNIT FROM THE SKID AND MOVE IT TO THE PLACE OF INSTALLATION.



CAUTION: ANY STAND, COUNTER OR OTHER DEVICE ON WHICH FRYER WILL BE LOCATED MUST BE DESIGNED TO SUPPORT THE WEIGHT OF THE FRYER.



CAUTION: SHIPPING STRAPS ARE UNDER TENSION AND CAN SNAP BACK WHEN CUT.



DANGER: THIS APPLIANCE MUST BE GROUNDED AT THE TERMINAL PROVIDED. FAILURE TO GROUND THE APPLIANCE COULD RESULT IN ELECTROCUTION AND DEATH.



WARNING: INSTALLATION OF THE UNIT MUST BE DONE BY PERSONNEL QUALIFIED TO WORK WITH ELECTRICITY. IMPROPER INSTALLATION CAN CAUSE INJURY TO PERSONNEL AND/OR DAMAGE TO EQUIPMENT. UNIT MUST BE INSTALLED IN ACCORDANCE WITH ALL APPLICABLE CODES.



NOTICE: The data plate is located behind access door over tank drain. The fryer voltage, wattage, serial number, wire size, and clearance specifications are on the data plate. This information should be carefully read and understood before proceeding with the installation.



NOTICE: The installation of any components such as a vent hood, grease extractors, fire extinguisher systems, must conform to their applicable National, State and locally recognized installation standards.



NOTICE: During the first few hours of operation you may notice a small amount of smoke coming off the melter, and a faint odor from the smoke. This is normal for a new melter and will disappear after the first few hours of use.



CAUTION: ALWAYS KEEP THE AREA NEAR THE APPLIANCE FREE FROM COMBUSTIBLE MATERIALS.



CAUTION: KEEP FLOOR IN FRONT OF EQUIPMENT CLEAN AND DRY. IF SPILLS OCCUR, CLEAN IMMEDIATELY, TO AVOID THE DANGER OF SLIPS OR FALLS.



WARNING: KEEP WATER AND SOLUTIONS OUT OF CONTROLS. NEVER SPRAY OR HOSE CONTROL CONSOLE, ELECTRICAL CONNECTIONS, ETC.



CAUTION: MOST CLEANERS ARE HARMFUL TO THE SKIN, EYES, MUCOUS MEMBRANES AND CLOTHING. PRECAUTIONS SHOULD BE TAKEN TO WEAR RUBBER GLOVES, GOGGLES OR FACE SHIELD AND PROTECTIVE CLOTHING. CAREFULLY READ THE WARNING AND FOLLOW THE DIRECTIONS ON THE LABEL OF THE CLEANER TO BE USED.



NOTICE: Service on this, or any other, LANG appliance must be performed by qualified personnel only. Consult your authorized service station directory or call the factory at 1-800-224-LANG (5264), or WWW.LANGWORLD.COM for the service station nearest you.



WARNING: BOTH HIGH AND LOW VOLTAGES ARE PRESENT INSIDE THIS APPLIANCE WHEN THE UNIT IS PLUGGED/WIRED INTO A LIVE RECEPTACLE. BEFORE REPLACING ANY PARTS, DISCONNECT THE UNIT FROM THE ELECTRIC POWER SUPPLY.



CAUTION: USE OF ANY REPLACEMENT PARTS OTHER THAN THOSE SUPPLIED BY LANG OR THEIR AUTHORIZED DISTRIBUTORS CAN CAUSE BODILY INJURY TO THE OPERATOR AND DAMAGE TO THE EQUIPMENT AND WILL VOID ALL WARRANTIES.



EQUIPMENT DESCRIPTION

ELECTRIC FRYER

COUNTER MODEL

- The fryer dimensions are 19" (48.25cm) High, 32" (81.25cm) Deep, 15" (38cm) wide.
- The Sides, Bottom, and Rear wall are constructed stainless steel.

FLOOR MODELS

- The interior dimension are 36" (91.5cm) High, 38" (96.5cm) Deep, 15" (38cm) wide.
- The Sides, Bottom, and Rear wall are constructed stainless steel.

CONTROLS

- Easy to use manual control knobs.
- Indicator lights for "Power", "Heat", and "Over-temperature".
- The fryer is supplied with an auxiliary power interrupt terminal, which when connected, automatically shuts off primary power to the fryer.

INSTALLATION

RECEIVING THE FRYER

Upon receipt, check for freight damage, both visible and concealed. Visible damage should be noted on the freight bill at the time of delivery and signed by the carrier's agent. Concealed loss or damage means loss or damage, which does not become apparent until the merchandise has been unpacked.

If concealed loss or damage is discovered upon unpacking, make a written request for inspection by the carrier's agent within 15 days of delivery. All packing material should be kept for inspection.

Do not return damaged merchandise to Lang Manufacturing Company. File your claim with the carrier.

Prior to un-crating, move the fryer as near its intended location as practical. The crating will help protect the unit from the physical damage normally associated with moving it through hallways and doorways.

ELECTRICAL CONNECTION

Electrical service may be made through a standard 1¼ inch conduit. A hole is provided through the rear panel.

A knockout is also provided in the bottom rear of the fryer, so that power may be brought in from below the unit.

Plug the hole on the rear panel when using bottom power entry.

Check the National Electrical Code for fuse or circuit breaker requirements.

A two pole terminal block is provided behind the rear access cover for connection to an external fire control system if required. A jumper is provided across these terminals when the fryer leaves the factory. The jumper on this terminal block is in series with the contactor coil circuits. If connection to a fire control system is required, remove this jumper and supply a relay contact closure to maintain this closed circuit. If the fire control system does not have this type output, a separate relay must be provided to interface the system. Use copper wire only.

CAUTION: **DO NOT APPLY POWER TO THESE TERMINAL. EXTERNAL POWER WILL DAMAGE THE FRYER CONTROL CIRCUITRY.**



Connect a ground lead to the green ground lug provided in the rear compartment.

These fryers are to be connected to three-phase power as follows:

Connect wires 1 and 4 to line 1, wires 2 and 5 to line 2, and wires 3 and 6 to line 3.

Please contact the factory for single-phase connections.

CAUTION: **DO NOT CONNECT TO A CIRCUIT OPERATING AT MORE THAN 150 VOLTS TO GROUND.**



PHASING

POWER SUPPLY	TERMINAL BLOCK	RANGE TOP
THREE PHASE	L1	1,4
	L2	2,5
	L3	3,6

START-UPS

C-28, F-28

Electric Fryer Start-Up

- 1. Verify correct phasing of unit.
- 2. Verify connections at plug and terminal block.
- 3. Incoming Voltage: Single Phase L1-L2_____
- Three Phase L1-L2_____ L2-L3_____ L3-L1_____
- 4. Verify amperage. L1_____ L2_____ L3_____

Model # _____ Date _____ Serial # _____

Store # _____ Tech Name _____
Contact _____ Company _____
Store Phone # _____ Service Company Phone # _____

Address _____

GENERAL OPERATION

Fill the fryer with cooking oil. There are two fill marks on the sides of the kettle. The oil level should be maintained between the upper and lower marks.

The power switch on the control box at the front of the fryer energizes the control circuits. When this switch is on, the “power” pilot lamp will be illuminated.

Turn the temperature selector dial on the thermostat to the desired temperature setting. This control is located above the elements at the rear of the kettle. The “heat” pilot lamp will illuminate indicating power is applied to the heating elements.

The lamp marked “overtemp” will illuminate if the oil reaches an over temperature condition. The over temperature thermostat shuts off the fryer before the oil reaches a dangerously high temperature.

The elements may be raised and locked in the up position. The latch is located on the rear top surface of the fryer and may be activated by lifting the handle at either side of the fryer.

A drain valve is provided at the left front of the fryer. Always turn the fryer power off before lifting the elements of draining the oil from the fryer.

On those models with automatic bracket lifts, the cooking times may be set from 1 to 16 minutes with the timer control dials.

Pressing down on the spring return elevator switches will lower the basket lifts. At the end of the time set on the dial the lift will return to the up position. The time cycle may be canceled at any time by pressing the elevator switch to the up position.

CONTROLS

Power Switch - A toggle switch used to turn the unit on and off.

Pilot Lights - Lights that are located in the rear control panel area.

Power: Lights up when the power switch is in the “ON” position.

Heat: Lights up when the element contactors engage.

Over-temp: Lights up when the over-temperature thermostat trips.

Test Switch - Optional on all models, it gives the user the ability to test the over-temperature thermostat by overriding the thermostat and allowing the oil to exceed normal operating temperatures.

SEQUENCE OF OPERATION

ELECTRIC FRYER

Power switch to “ON” position.

208/240 VAC to “**POWER**” pilot lamp.

208/240 VAC to Thermostat through Over-Temperature thermostat.

Thermostat Set.

208/240 VAC to “**HEAT**” pilot lamp.

208/240 VAC to Contactors.

Contactors Energize.

208/240 VAC to Elements.

Elements Energize.

Fryer heats up.

TROUBLESHOOTING

Will not heat

PROBABLE CAUSE	CORRECTIVE ACTION
Incorrect voltage	<ul style="list-style-type: none"> ➤ Confirm that correct voltage is coming to unit. ➤ Confirm that unit is phased correctly.
Defective Fuses	<ul style="list-style-type: none"> ➤ Confirm that fuses have 208/240 VAC to it. ➤ Check fuses for proper operation.
Defective Power Switch	<ul style="list-style-type: none"> ➤ Confirm that switch has 208/240 VAC to it. ➤ Check switch for proper operation.
Defective Over temperature thermostat	<ul style="list-style-type: none"> ➤ Confirm that thermostat has 208/240 VAC to it. ➤ Confirm that over temperature thermostat is closed and working properly.
Defective Thermostat	<ul style="list-style-type: none"> ➤ Confirm that thermostat has 208/240 VAC to it. ➤ Check that thermostat is operating properly.
Defective Contactor	<ul style="list-style-type: none"> ➤ Confirm that contactor has 208/240 VAC to it. ➤ Check contactor for normal operation. (554 Ω)
Defective Element	<ul style="list-style-type: none"> ➤ Confirm that elements are wired correctly. ➤ Confirm that element has 208/240 VAC to it. ➤ Confirm that there are no broken wires to the elements. ➤ Check Element for continuity.

Overheating

PROBABLE CAUSE	CORRECTIVE ACTION
Bulb out of Placement	<ul style="list-style-type: none"> ➤ Confirm that bulb is centered in element. ➤ Confirm that bulb is secured in clips.
Oil level to Low	<ul style="list-style-type: none"> ➤ Confirm that oil levels are at proper level.
Sticking contactor	<ul style="list-style-type: none"> ➤ Confirm that points are not pitted. ➤ Replace if necessary.
Food Stuck between Element and bulb.	<ul style="list-style-type: none"> ➤ Remove food between element.

TECHNICAL DATA

ELEMENT RESISTANCE

Part Number	Voltage	Amps	Resistance
➤ 11110-43	208 Volts	19	10.6 Ω
➤ 11110-41	240 Volts	7.6	29.6 Ω
➤ 11110-39	480 Volts	8	56.6 Ω
➤ 11110-46	415 Volts	9.5	40.1 Ω
➤ 11110-45	380 Volts	10.5	35.6 Ω

CONTACTOR RESISTANCE

Part #	Voltage	Coil
30700-05	208/240 Volts	554 Ω

TRANSFORMER RESISTANCE

Part #	Primary	Resistance	Secondary	Resistance
31400-04	480 Volts	66 Ω	240 Volts	16 Ω

FRYER LINE AMPERAGE, AND WATTAGE

ALL SERIES 28 ELECTRIC FRYERS															
Model #	THREE PHASE LOADING			Total K.W.	NOMINAL AMPS PER LINE									SINGLE PHASE	
					208 VOLTS			240 VOLTS			480 VOLTS			208V	240V
	K.W. PER PHASE				L1	L2	L3	L1	L2	L3	L1	L2	L3	See	See
L1-L2	L2-L3	L3-L1		L1	L2	L3	L1	L2	L3	L1	L2	L3	Factory	Factory	
-28	4.0	4.0	4.0	12.0	33.3	33.3	33.3	28.9	28.9	28.9	14.4	14.4	14.4	Factory	Factory

WIRING DIAGRAM 208/240

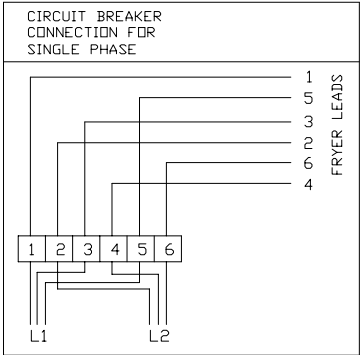
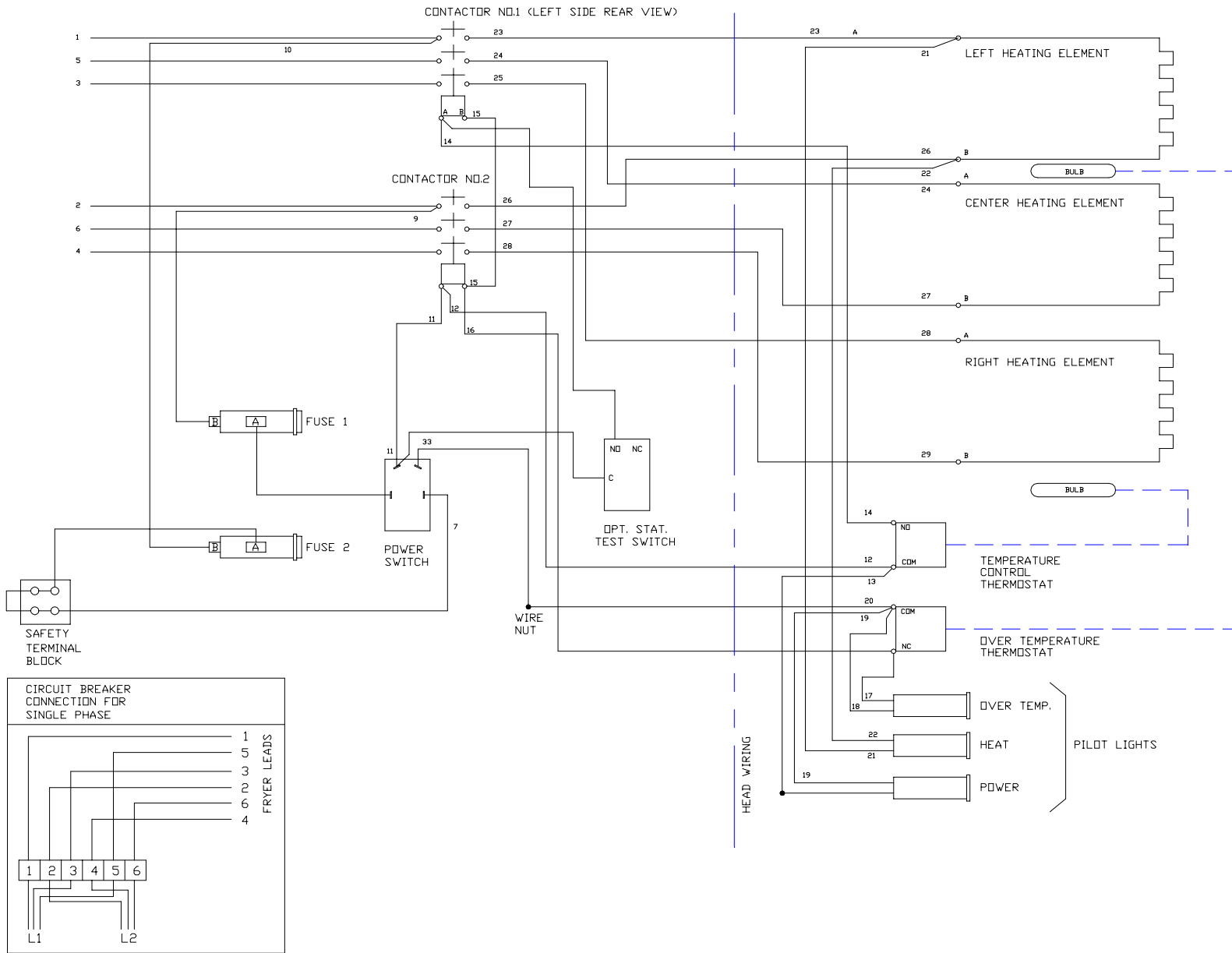

SERVICE CONNECTIONS		
THREE PHASE	L1	1,4
	L2	2,5
	L3	3,6
SINGLE PHASE	L1	1,3,5
	L2	2,4,6

WIRING DIAGRAM 480

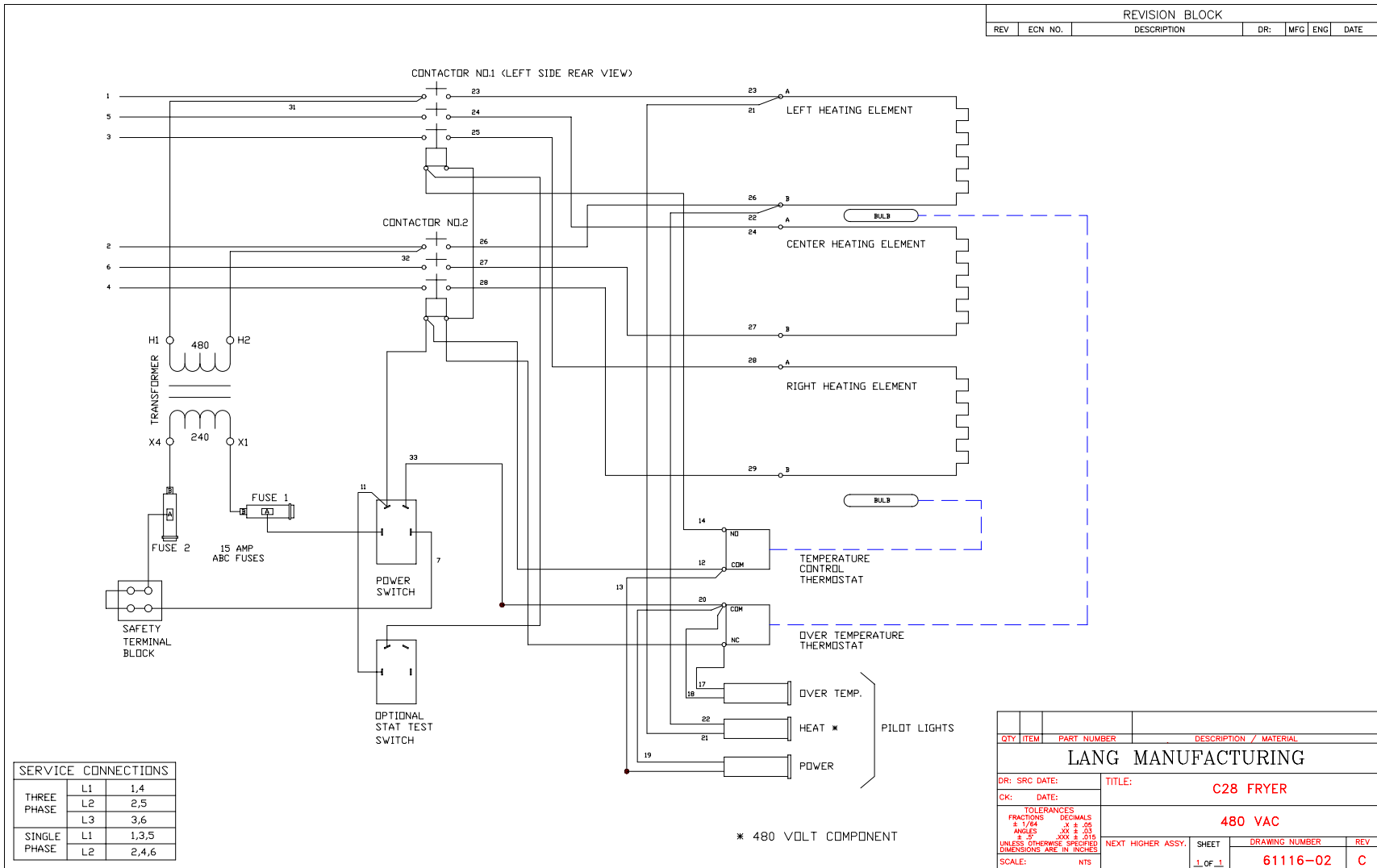

C-28**ELECTRIC FRYER**

DESCRIPTION	PART NO.
Element C28 Fryer 480 Volt 4000 Watts	11110-39
Element C28 Fryer 208 Volt 4000 Watts	11110-43
Element C28 Fryer 240 Volt 4000 Watts	11110-44
Element C28 Fryer 380 Volt 4000 Watts	11110-45
Motor Lift Assembly	30200-02
Switch Micro Lift	30301-01
Switch Toggle Lift	30303-02
Switch Toggle On-Off	30303-06
Switch Toggle On-Off Metal Handle (Marine Only)	30303-11
Boot Threaded for Metal Toggle Switch	30303-15
Switch Temperature Control 12 Position 180-400°F (Remote Control Units Only)	30304-18
Thermostat Safety 450°F Open (Remote Control Units Only)	30401-13
Thermostat Safety 425°F Open (Marine Only)	30401-19
Thermostat Over-Temp. Modification Kit	60101-26
Thermostat 400°F Fryer	30402-12
Terminal Strip 2 Pole	30500-01
Terminal Block 2 Pole	30500-08
Terminal Strip 3 Pole	30501-02
Relay 24 VDC	30600-01
Contactator 3 Pole 208/240 VAC	30700-05
Contactator 3 Pole 24 VAC (Remote Control Units Only)	30700-06
Fuse 15 Amp	30900-01
Fuse 15 Amp 300 Volt (Remote Control Units Only)	30900-10
Fuse 3 Amp	30900-15
Fuse Holder 15 Amp	30901-02
Fuse Holder 15 Amp (Remote Control Units Only)	30901-08
Transformer 480/240 VAC	31400-04
Transformer 240/24 VAC	31400-10
Transformer 480/24 VAC (Remote Control Units Only)	31400-15
Transformer 380/240 VAC	31400-17
Pilot Light 208/240V 6" Lead Black Body	31601-01
Pilot Light 480V 6" Lead Black Body	31601-02
Pilot Light 28 VAC (Remote Control Units Only)	31601-07
Circuit Breaker 480 Volt 2/10Amp 2 Pole (Marine Only)	31800-07
Circuit Board Assembly Timer	40100-07
Circuit Board Assembly Timer Mother	40100-08
Circuit Board Temperature Control (Remote Control Units Only)	40101-19
Potentiometer Timer	40900-06
Probe Temperature Sensor (Remote Control Units Only)	41100-23
Grab Bar Assembly 15" (Marine Units)	50300-49
Lift Rod	50800-09
Lift Rod Top	50800-18
Basket Hanger Assembly Non-Lift	51100-02
Basket Hanger Assembly Lift	51100-03
Drain Elbow Assembly	51100-16
Lift Handle	60102-21
Lower Element Clip	60102-31
Bottom Element Clamp	60102-32

C-28**ELECTRIC FRYER**

DESCRIPTION	PART NO.
Element Clamp	60102-321
Upper Element Clip	60102-78
Thermostat Capillary Tube Spacer	60102-79
Capillary Tube Spacer	60102-80
Small Capillary Tube Clip	60102-81
High Limit Thermostat Spacer	60102-82
Bucket Fryer	60102-800
Panel Label C28	60301-16
Panel Label C28L	60301-18
Panel Label (Remote Control Units Only)	60301-103
Quick Disconnect Coupler 1"	70100-01
Quick Disconnect Nipple 1"	70100-02
Rulon Bearing for Basket Lift	70200-02
Valve Manual Drain	70400-01
Knob Temperature Control	70701-06
Knob Timer	70701-08
Knob Time Control (Remote Control Units Only)	70701-27
Plastic Capillary Tube Bushing	70801-05
Cap Drain Plug	70900-01
Roll Pin 1/4" X 1	71800-02