

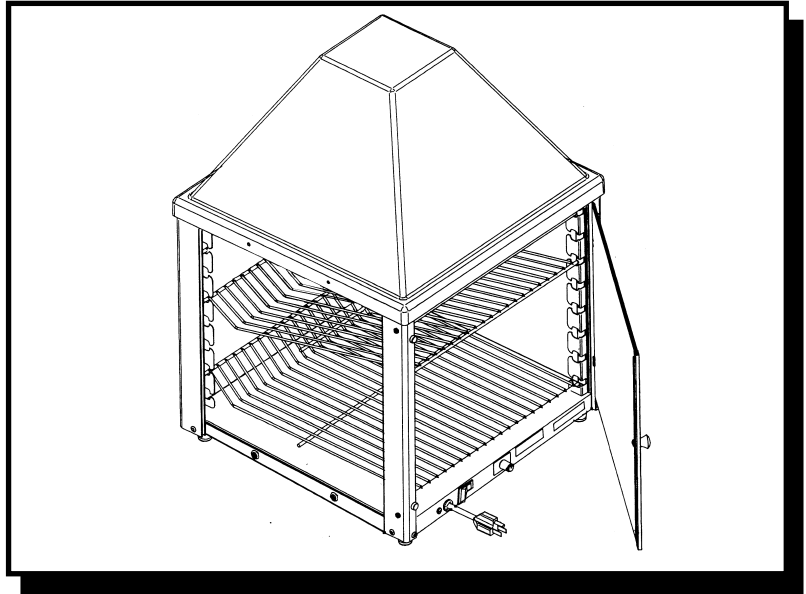

**INSTALLATION
AND
OPERATING
INSTRUCTIONS**



Model: DWC-17

WARMING CABINET

INTENDED FOR OTHER THAN HOUSEHOLD USE

**RETAIN THIS MANUAL FOR FUTURE REFERENCE
UNIT MUST BE KEPT CLEAR OF COMBUSTIBLES AT ALL TIMES**

TABLE OF CONTENTS

Safety Precautions.....	2
General Information.....	2
Installation.....	2
Operation Instructions.....	3
Cleaning Instructions.....	3
Troubleshooting.....	4
Replacement Parts List.....	4
Wiring Diagram.....	6
Warranty Procedure.....	6
Warranty.....	7

! WARNING: Improper installation, adjustment, alteration, service or maintenance can cause property damage, injury or death. Read the Installation, Operating and Maintenance Instructions thoroughly before installing or servicing this equipment. **!**

This equipment has been engineered to provide you with year-round dependable service when used according to the instructions in this manual and standard commercial kitchen practices.

Phone: +1 (214) 421-7366
 Fax: +1 (214) 565-0976
 Toll Free: +1 (800) 527-2100
 Website: www.apwwyott.com
 E-mail: info@apwwyott.com

P/N 77612040 9/05

APW WYOTT
 729 Third Avenue
 Dallas, TX 75226

IMPORTANT FOR FUTURE REFERENCE

Please complete this information and retain this manual for the life of the equipment. For Warranty Service and/or Parts, this information is required.

Model Number

Serial Number

Date Purchased

SAFETY PRECAUTIONS

APW Wyott equipment is designed, built and sold for commercial use and should be operated by trained personal only. Make sure all CAUTIONS, WARNINGS and operating instructions are clearly posted near each unit to insure proper operation and reduce the chance of personal injury and/or equipment damage. Always disconnect power before cleaning or servicing the unit. Surfaces will remain hot after power has been removed, allow unit to cool before cleaning or servicing. Never clean the unit by immersing it in water. The unit is not protected against water jets; DO NOT CLEAN UNIT WITH A WATER JET. Always clean equipment before first use.

GENERAL INFORMATION

Check the rating label for your model designation and electrical rating. Rating Label is located on the inside frame of the unit.

Overall dimensions:

18.25" (46.4 cm) W x 18.5" (47.0 cm) D x 25.12" (63.8 cm) H

Electrical ratings:

120VAC, 660W, 60Hz, NEMA 5-15 Plug

Power Cord:

6 foot, 3 wire grounded cord. If the supply cord is damaged, the manufacturer or an authorized service agent or a similarly qualified person must replace it in order to avoid a hazard.

Shipping Weight: 54 Lbs. (24.5 Kg.)

INSTALLATION

1. Unpack Unit
Remove unit from shipping carton, unwrap loose parts and remove any packing tape, plastic wrap and nylon tie-down.

NOTE: Prior to initial start-up, all removable parts and interior surfaces should be cleaned with warm soapy water to remove manufacturing oils, then rinsed and dried thoroughly. Please follow the cleaning instructions on page 3.

2. Switch the position of the door knobs from inside to outside by using a screw driver. The knobs are on the inside for shipping purposes.

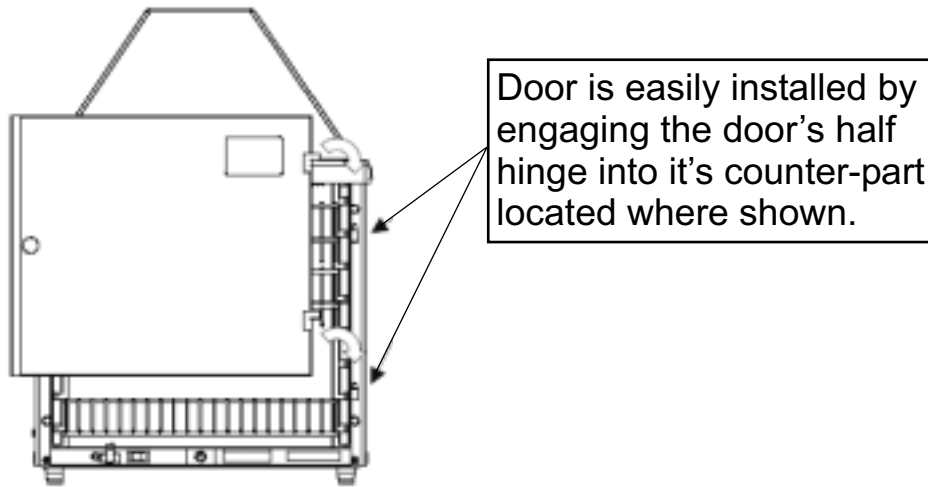

OPERATION INSTRUCTIONS

3. Turn Main Power Switch on. Set Temperature Control knob to desired temperature. An initial setting of 4 or 5 is recommended. Final settings will depend upon product weight, consistency, and personal preference.
4. This unit is intended to keep warm food warm. It is not intended to reheat product.
5. PLACE PRODUCT ON THE DISPLAY RACK OR SHEET PANS FOR DISPLAY. Do not place food directly on inside bottom of the unit.
6. Use HOT PADS or OVEN MITTS when removing rack or other metal objects from the warmer. Use Utensils to remove Product.

NOTE: Should the temperature setting be changed, allow several minutes for the temperature to adjust. Once the desired setting has been achieved, note the number and keep it there.

CLEANING INSTRUCTIONS

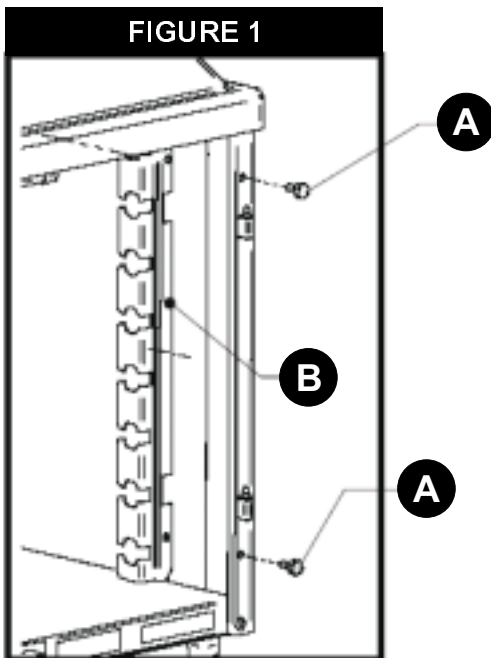

WARNING: Make sure the unit is in the OFF position and has been off for ONE hour.

DO NOT attempt to clean the unit if the unit components are too hot to touch.

Never spray water on the unit or controls. Damage to the unit as well as injury could occur. Injury and burns may occur if you do not follow this instruction sheet.

Cleaning should be done Daily.

1. Remove door by pulling it, in an upward direction. Start the lifting motion with the door in the open position.
2. In order to effectively clean the interior of the unit, you will need to remove all four "Corner Rack Supports", which are fastened with 2 thumbscrews each.
3. To remove the "Corner Rack Supports" (Item B in Fig.1), turn the thumbscrews in a counter-clockwise direction. Repeat the process for all four "Corner Rack Supports". Note that each "Corner Rack Support" is fastened by two thumb screws which are shown by (Item A in Fig.1)
4. Clean with warm soapy water and a soft cloth only.
5. **DO NOT USE ANY** ammonia, alcohol, or chlorine type cleaner will cause cracking of the enclosure and door(s).
6. Once the interior of the cabinet, along with "Corner Rack Supports" have been cleaned in the fashion described above, re-install all four of them using the thumbscrews provided with the unit.

TROUBLESHOOTING

Always ask and check the following:

1. Is the unit connected to a live power source of the proper voltage?
2. Check the circuit breaker.
3. Is power switch "ON" and light glowing?
4. Check the rating label. Is the unit connected to the correct power source?
5. If the above checks out, and you still have problems, call an APW Wyott authorized service agent.

REPLACEMENT PARTS LIST - DWC-17 WARMING CABINET

ITEM	PART NUMBER	DESCRIPTION	QUANTITY
1	77612021	TOP	1
2	77612012	TOP SUB ASSEMBLY	1
3	85830	HEATING ELEMENT	1
4	69127	HIGH-LIMIT SAFETY SWITCH	1
5	85836	BLOWER MOTOR / FAN ASSEMBLY	1
6	75916	LAMP, 40 W, COATED	1
7	46879	LAMP SOCKET	1
8	66725	LIGHT GUARD WIRE RACK	1
9	88890	THUMBSCREW FOR LIGHT	1
10	69128	THERMOMETER	1
11	77612027	PLASTIC DOOR	1
12	77612026	DISPLAY RACK	2
13	89408	MAIN SWITCH, LIGHT ROCKER	1
14	89101	STRAIN RELIEF BUSHING	1
15	55947	POWER CORDSET	1
16	69155	TEMPERATURE CONTROL THERMOSTAT	1
17	89499	INDICATOR KNOB	1
18	77612033	CORNER RACK SUPPORT	4
19	77612041	THUMB SCREW FOR RACK SUPPORTS	8

EXPLODED VIEW - DWC-17 WARMING CABINET

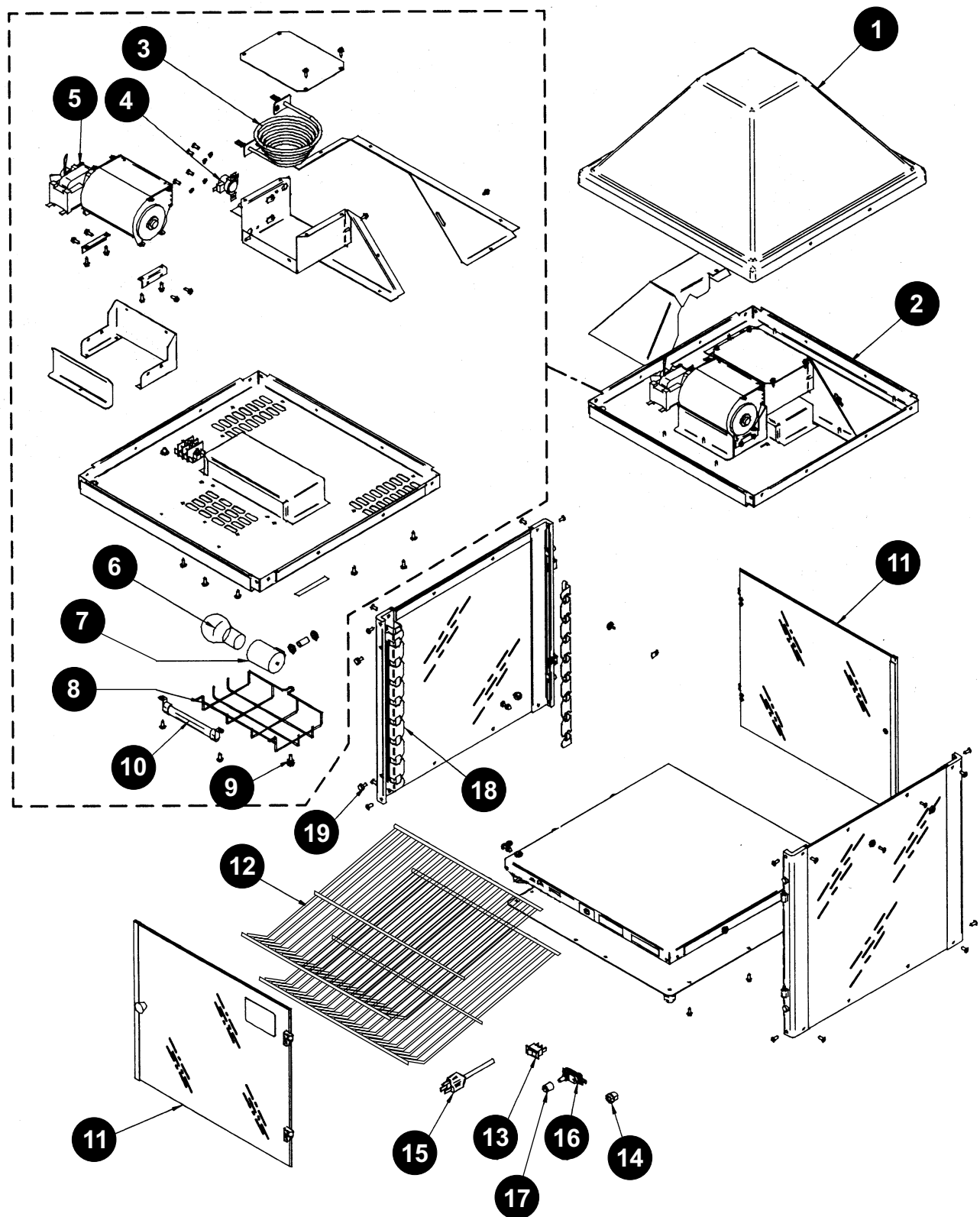

WIRING DIAGRAM - DWC-17 WARMING CABINET

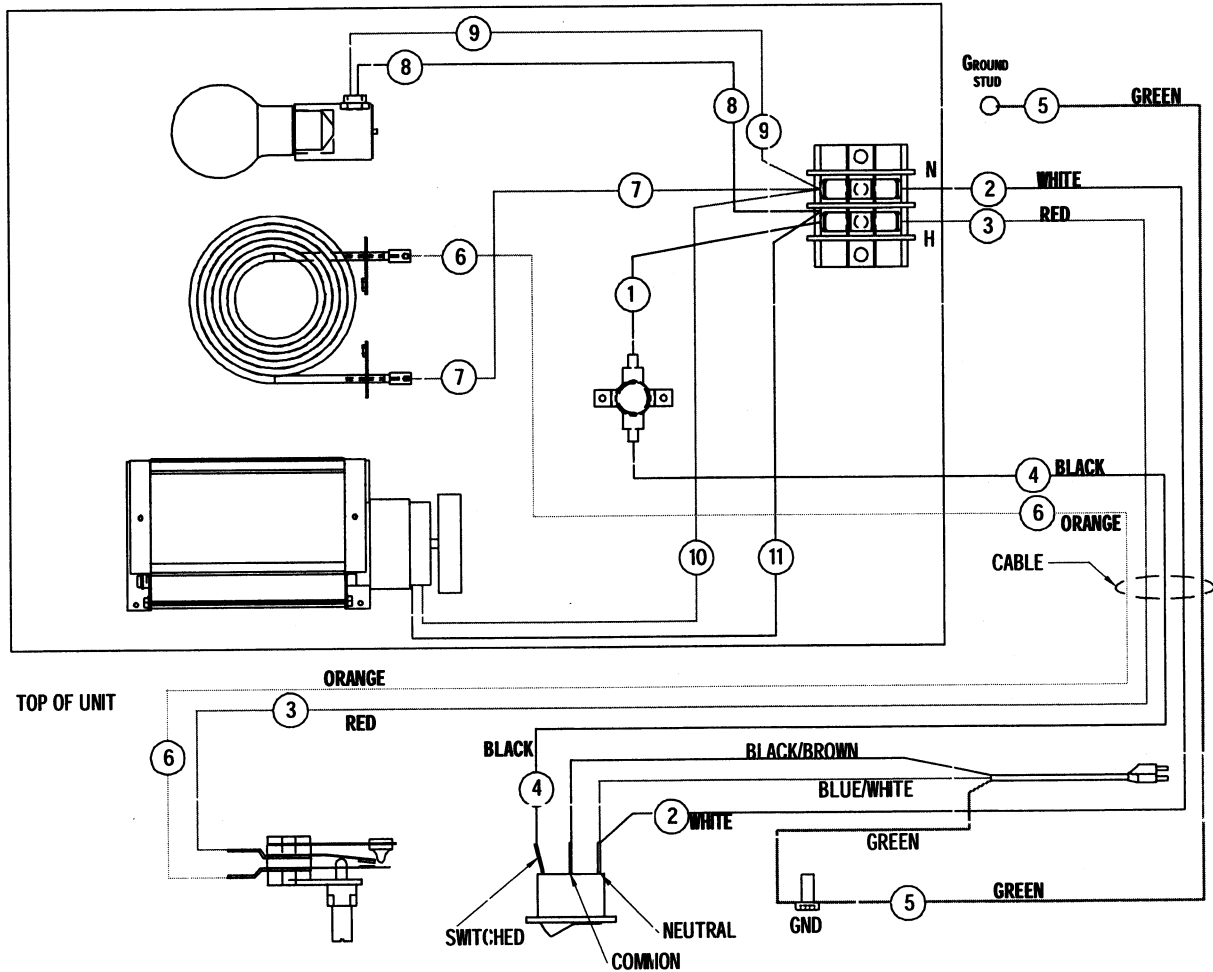

WARRANTY PROCEDURE

If warranty service is needed on your APW/Wyott equipment, follow these steps:

1. Secure the model and serial number from the rating label on your warming cabinet.
2. Consult the enclosed directory, find the service agency nearest you, call the number listed or the 24-hour toll free service hot line, 1-800-733-2203. If there is not a service agency listed for your area, the parts distributor will provide service for your warming cabinet.
3. To order parts, consult the enclosed directory. The parts distributor is listed at the beginning of each state listing. The parts distributors have a complete stock of parts for your warming cabinet.

APW WYOTT EQUIPMENT LIMITED WARRANTY

APW Wyott Foodservice Equipment Company warrants its equipment against defects in materials and workmanship, subject to the following conditions:

This warranty applies to the original owner only and is not assignable.

Should any product fail to function in its intended manner under normal use within the limits defined in this warranty, at the option of APW Wyott such product will be repaired or replaced by APW Wyott or its Authorized Service Agency. APW Wyott will only be responsible for charges incurred or service performed by its Authorized Service Agencies. The use of other than APW Wyott Authorized Service Agencies will void this warranty and APW Wyott will not be responsible for such work or any charges associated with same. The closest APW Wyott Authorized Service Agent must be used.

This warranty covers products shipped into the 48 contiguous United States, Hawaii, metropolitan areas of Alaska and Canada. There will be no labor coverage for equipment located on any island not connected by roadway to the mainland.

Warranty coverage on products used outside the 48 contiguous United States, Hawaii, and metropolitan areas of Alaska and Canada may vary. Contact the international APW Wyott distributor, dealer, or service agency for details.

Time Period

One year for parts and one year for labor, effective from the date of purchase by the original owner. The Authorized Service Agency may, at their option, require proof of purchase. Parts replaced under this warranty are warranted for the un-expired portion of the original product warranty only.

Exceptions

- ***Gas/Electric Cookline:** Models GCB, GCRB, GF, GGM, GGT, CHP-H, EF, EG, EHP. Three (3) Year Warranty on all component parts, except switches and thermostats. (2 additional years on parts only. No labor on second or third year.)
- ***Broiler Briquettes, Rock Grates, Cooking Grates, Burner Shields, Fireboxes:** 90 Day Material Only. No Labor.
- ***Heat Strips:** Models FD, FDL, FDD, FDDL. Two (2) Year Warranty on element only. No labor second year.
- ***Glass Windows, Doors, Seals, Rubber Seals, Light Bulbs:** 90 Day Material Only. No Labor.

In all cases, parts covered by extended warranty will be shipped FOB the factory after the first year.

Portable Carry In Products

Equipment weighing over 70 pounds or permanently installed will be serviced on-site as per the terms of this warranty. Equipment weighing 70 pounds or under, and which is not permanently installed, i.e. with cord and plug, is considered portable and is subject to the following warranty handling limitations. If portable equipment fails to operate in its intended manner on the first day of connection, or use, at APW Wyott's option or its Authorized Service Agency, it will be serviced on site or replaced.

From day two through the conclusion of this warranty period, portable units must be taken to or sent prepaid to the APW Wyott Authorized Service Agency for in-warranty repairs. No mileage or travel charges are allowed on portable units after the first day of use. If the customer wants on-site service, they may receive same by paying the travel and mileage charges. Exceptions to this rule: (1) countertop warmers and cookers, which are covered under the Enhanced Warranty Program, and (2) toasters or rollergrills which have in store service.

Exclusions

The following conditions are not covered by warranty:

- *Equipment failure relating to improper installation, improper utility connection or supply and problems due to ventilation.
- *Equipment that has not been properly maintained, calibration of controls, adjustments, damage from improper cleaning and water damage to controls.
- *Equipment that has not been used in an appropriate manner, or has been subject to misuse or misapplication, neglect, abuse, accident, alteration, negligence, damage during transit, delivery or installation, fire, flood, riot or act of god.
- *Equipment that has the model number or serial number removed or altered.

If the equipment has been changed, altered, modified or repaired by other than an Authorized Service Agency during or after the warranty period, then the manufacturer shall not be liable for any damages to any person or to any property, which may result from the use of the equipment thereafter.

This warranty does not cover services performed at overtime or premium labor rates. Should service be required at times which normally involve overtime or premium labor rates, the owner shall be charged for the difference between normal service rates and such premium rates. APW Wyott does not assume any liability for extended delays in replacing or repairing any items beyond its control.

In all cases, the use of other than APW Wyott Authorized OEM Replacement Parts will void this warranty.

This equipment is intended for commercial use only. Warranty is void if equipment is installed in other than commercial application.

Water Quality Requirements

Water supply intended for a unit that has in excess of 3.0 grains of hardness per gallon (GPG) must be treated or softened before being used. Water containing over 3.0 GPG will decrease the efficiency and reduce the operation life of the unit.

Note: Product failure caused by liming or sediment buildup is not covered under warranty.

"THE FOREGOING WARRANTY IS IN LIEU OF ANY AND ALL OTHER WARRANTIES EXPRESSED OR IMPLIED INCLUDING ANY IMPLIED WARRANTY OF MERCHANTABILITY OR FITNESS FOR PARTICULAR PURPOSES AND CONSTITUTES THE ENTIRE LIABILITY OF APW WYOTT. IN NO EVENT DOES THE LIMITED WARRANTY EXTEND BEYOND THE TERMS STATED HEREIN."

9/05



Phone: +1 (214) 421-7366
Fax: +1 (214) 565-0976
Toll Free: +1 (800) 527-2100
Website: www.apwwyott.com
E-mail: info@apwwyott.com

APW WYOTT
729 Third Avenue
Dallas, TX 75226